



V-Plate



Parts ID Manual

Revision: D

© Copyright 2024 by DEMTECH Services, Inc.

All Rights Reserved

Scope of Manual:

This manual contains procedures for safety, general unpacking, set-up, and operation of your DEMTECH Services, Inc. V-Plate.

The text of this publication, or any part thereof, may not be reproduced or transmitted in any form or by any means, electronic or mechanical, including photocopying, recording, storage in an information retrieval system, or otherwise, without prior written permission of DEMTECH Services, Inc.

Notice

Patents have been granted and/or patent applications are pending or are in the process of preparation on all DEMTECH Services, Inc. developments.

The material in the manual is for informational purposes only and is subject to change without notice.

DEMTECH Services, Inc. assumes no responsibility for any errors that may appear in this manual.

Manual Number: **VP-PARTS ID MANUAL, Revision: C**

DEMTECH Services, Inc.
6414 Capitol Avenue Diamond Springs, CA 95619 U.S.A.
Telephone: (530) 621-3200
Toll Free: (888) 324-9353
Fax: (530) 621-0150
Web Site: www.demtech.com

TABLE OF CONTENTS

1 ORDER INSTRUCTIONS.....1

2 SELECT A MACHINE BELOW TO SEE ITS REPLACEMENT PARTS1

2.1 VP-180SC-24HVC – ASSY, V-PLATE VACUUM TESTER, SELF CONTAINED, 24”, 110V, HI-VAC (Parts ID)2

2.2 VP-180SC-24HVC – ASSY, V-PLATE VACUUM TESTER, SELF CONTAINED, 24”, 110V, HI-VAC (Parts List)3

2.3 VP-180SC-24HVC.2 – ASSY, V-PLATE VACUUM TESTER, SELF CONTAINED, 24”, 220V, HI-VAC (Parts ID)4

2.4 VP-180SC-24HVC.2 – ASSY, V-PLATE VACUUM TESTER, SELF CONTAINED, 24”, 220V, HI-VAC (Parts List) ...5

2.5 VP-180SC-24HVC.1 – ASSY, V-PLATE VACUUM TESTER, SELF CONTAINED, 24”, HI-VAC, W/O MOTOR (Parts ID).....6

2.6 VP-180SC-24HVC.1 – ASSY, V-PLATE VACUUM TESTER, SELF CONTAINED, 24”, HI-VAC, W/O MOTOR (Parts List).....7

2.7 VP-180SC-30HVC – ASSY, V-PLATE VACUUM TESTER, SELF-CONTAINED, 30”, 110V, HI-VAC (Parts ID)8

2.8 VP-180SC-30HVC – ASSY, V-PLATE VACUUM TESTER, SELF-CONTAINED, 30”, 110V, HI-VAC (Parts List)9

2.9 VP-180SC-30HVC.2 – ASSY, V-PLATE VACUUM TESTER, SELF-CONTAINED, 30”, 220V, HI-VAC (Parts ID) ...10

2.10 VP-180SC-30HVC.2 – ASSY, V-PLATE VACUUM TESTER, SELF-CONTAINED, 30”, 220V, HI-VAC (Parts List) .11

2.11 VP-180SC-30HVC.1 – ASSY, PLATE, VACUUM, 30”, W/O MOTOR (Parts ID) 12

2.12 VP-180SC-30HVC.1 – ASSY, PLATE, VACUUM, 30”, W/O MOTOR (Parts List) 13

2.13 VP-225HV/A – ASSY, VACUUM MOTOR, 110V, HI-VAC (Parts ID)14

2.14 VP-225HV/A – ASSY, VACUUM MOTOR, 110V, HI-VAC (Parts List)15

2.15 VP-220HV.2/A – ASSY, VACUUM MOTOR, 220V, HI-VAC (Parts ID)16

2.16 VP-220HV.2/A – ASSY, MOTOR, 220V, HI-VAC (Parts List)17

2.17 VP-240HV/A – ASSY, LID, VACUUM MOTOR, 110V, HI-VAC (Parts ID)..... 18

2.18 VP-240HV/A – ASSY, LID, VACUUM MOTOR, 110V, HI-VAC (Parts List)..... 19

2.19 VP-240HV.2/A – ASSY, LID, VACUUM MOTOR, 220V, HI-VAC (Parts ID)20

2.20 VP-240HV.2/A – ASSY, LID, VACUUM MOTOR, 220V, HI-VAC (Parts List)21

2.21 VP-90-12C - ASSY, V-PLATE TESTING SYSTEM, 12” X 90° (Parts ID) 22

2.22 VP-90-12C - ASSY, V-PLATE TESTING SYSTEM, 12" X 90° (Parts List) 23

2.23 VP-90-18C – ASSY, V-PLATE TESTING SYSTEM, 18" X 90° (Parts ID)..... 24

2.24 VP-90-18C – ASSY, V-PLATE TESTING SYSTEM, 18" X 90° (Parts List)..... 25

2.25 VP-180-24C – ASSY, V-PLATE VACUUM TESTER, 24", FLAT, NON SELF-CONTAINED (Parts ID)..... 26

2.26 VP-180-24C – ASSY, V-PLATE VACUUM TESTER, 24", FLAT, NON SELF-CONTAINED (Parts List) 27

2.27 VP-180-30C – ASSY, V-PLATE VACUUM TESTER, 30" FLAT, NON SELF-CONTAINED (Parts ID) 28

2.28 VP-180-30C – ASSY, V-PLATE VACUUM TESTER, 30" FLAT, NON SELF-CONTAINED (Parts List) 29

1 Order Instructions

Refer to the diagrams and related parts lists on the following pages to identify replacement parts for the V-Plate. To locate a part, find it visually on the exploded assembly diagram and note its Reference Number. Next refer to the assemblies parts list to identify the corresponding Part Number using the Reference Number. When ordering parts, be sure to specify the Part Number not the Reference Number. ‘*NS-Hardware*’ refers to non-stock items, these parts are still available for order, please provide the part description to order NS-Hardware items.

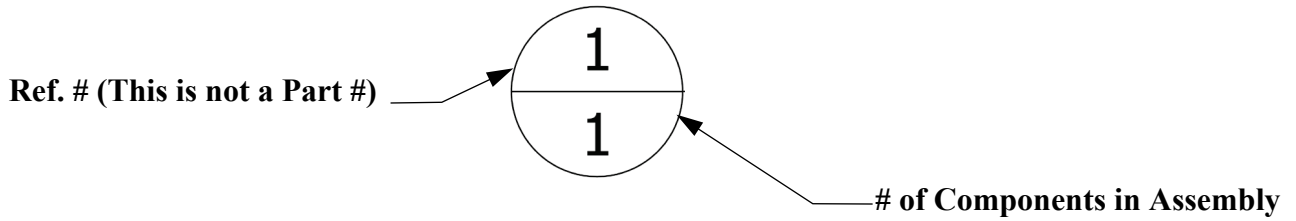

2 Select a Machine below to see its replacement parts

- Select  on the top left of any page to return to the home page.



[VP-180SC-24HVC \(110V\)](#)
[VP-180SC-24HVC.2 \(220V\)](#)



[VP-180SC-30HVC \(110V\)](#)
[VP-180SC-30HVC.2 \(220V\)](#)



[VP-180-24C](#)



[VP-180-30C](#)

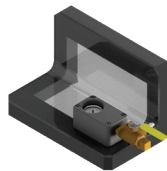

[VP-90-12C](#)

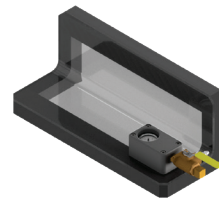

[VP-90-18C](#)

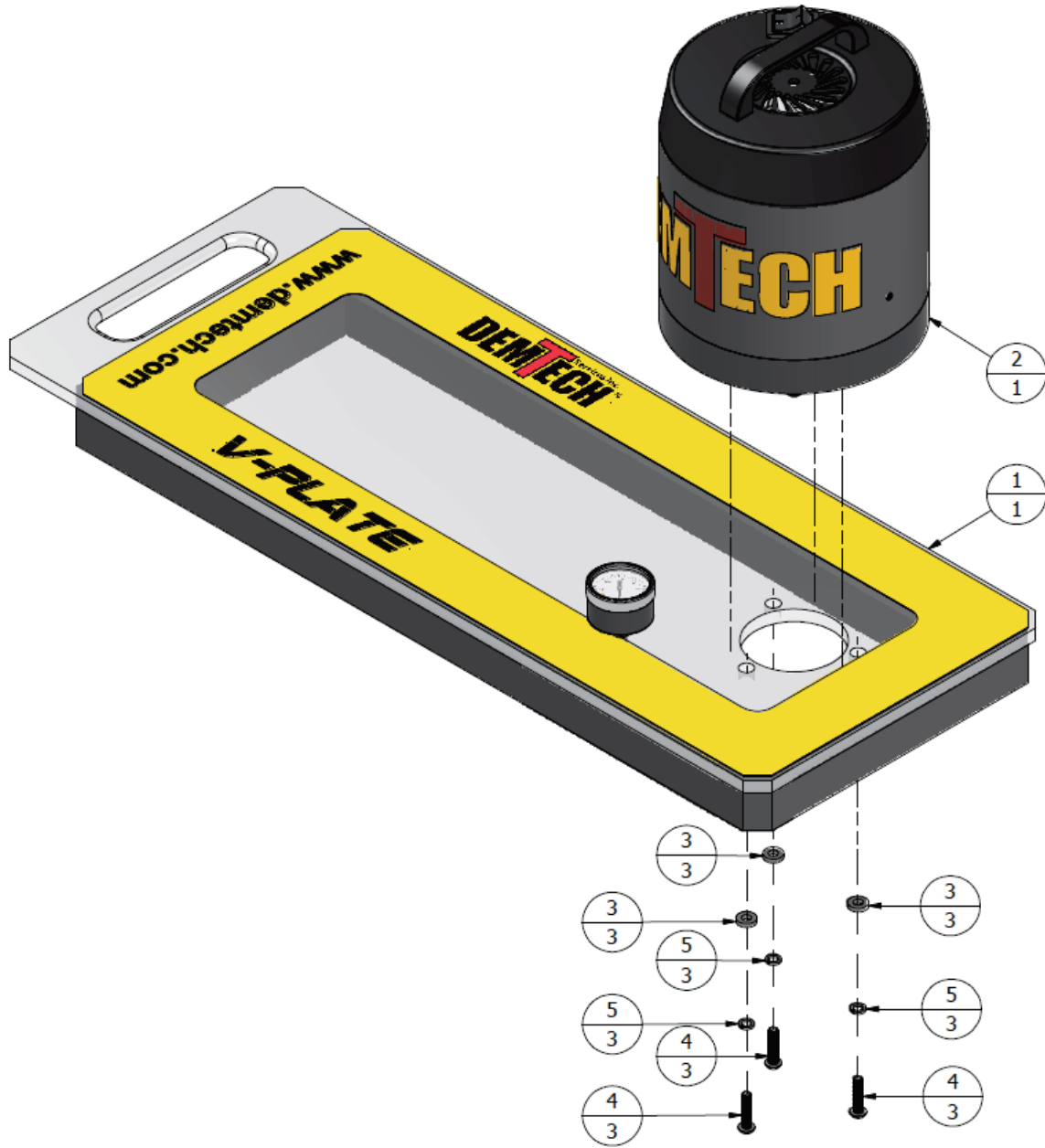

2.1 VP-180SC-24HVC – ASSY, V-PLATE VACUUM TESTER, SELF CONTAINED, 24”, 110V, HI-VAC (Parts ID)



PARTS LIST			
REF. NO	PART NO	DESCRIPTION	QTY
1	VP-180SC-24HVC.1	ASSY, PLATE, VACUUM, 24", W/O MOTOR	1
2	VP-225HV/A	ASSEMBLY, VACUUM MOTOR, 110V, HI-VAC	1
3	NS-HARDWARE	WASHER, OVERSIZED, M6, 18-8 STAINLESS	3
4	NS-HARDWARE	SCREW, BUTTON HEAD, M6-1.0 X 25mm	3
5	NS-HARDWARE	WASHER, SPLIT LOCK, M6, 18-8 STAINLESS	3

2.2 VP-180SC-24HVC – ASSY, V-PLATE VACUUM TESTER, SELF CONTAINED, 24”, 110V, HI-VAC (Parts List)

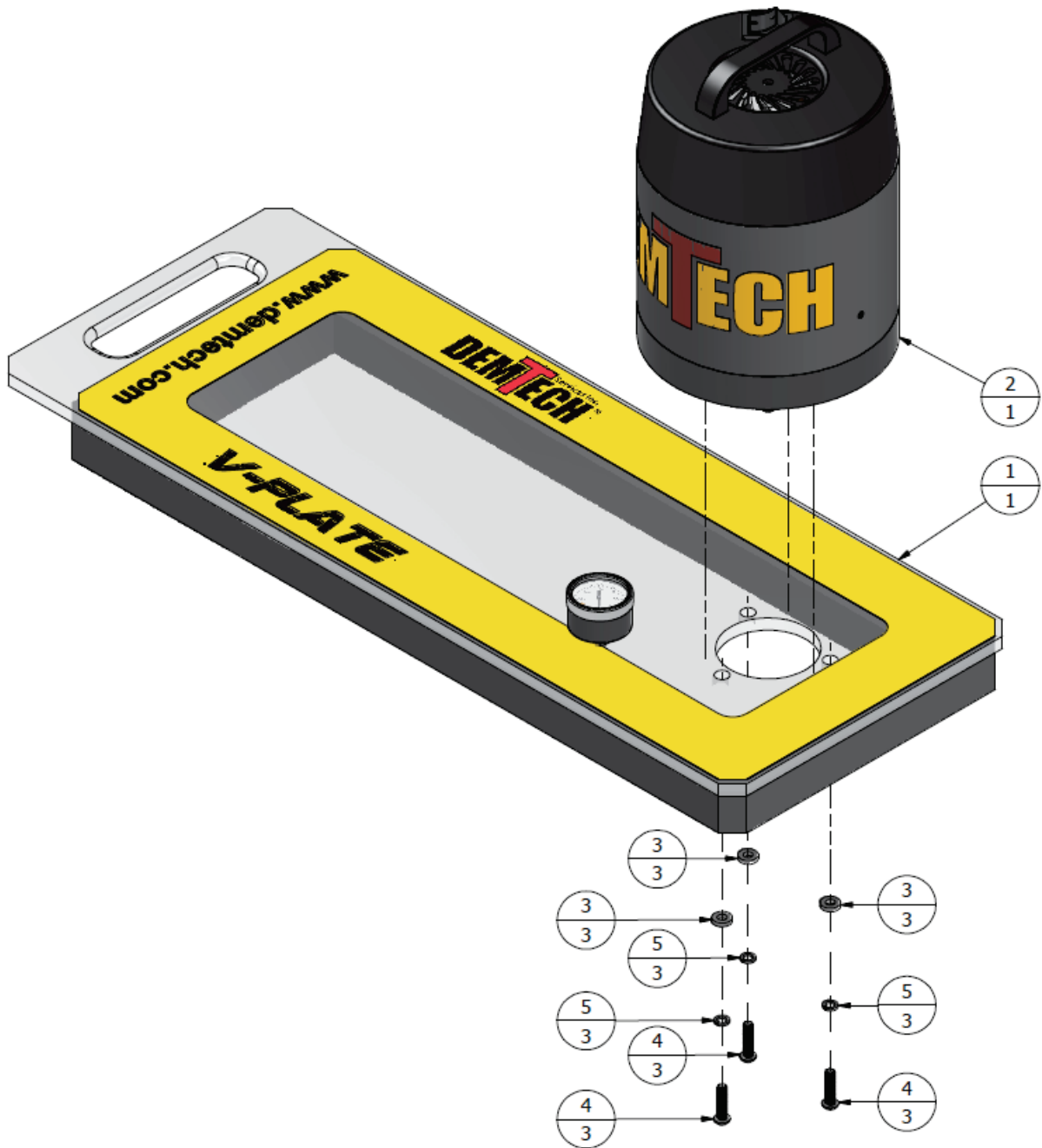

2.3 VP-180SC-24HVC.2 – ASSY, V-PLATE VACUUM TESTER, SELF CONTAINED, 24”, 220V, HI-VAC (Parts ID)



PARTS LIST			
REF. NO	PART NO	DESCRIPTION	QTY
1	VP-180SC-24HVC.1	ASSY, PLATE, VACUUM, 24", W/O MOTOR	1
2	VP-220HV.2/A	ASSEMBLY, VACUUM MOTOR, 220V, HI-VAC	1
3	NS-HARDWARE	WASHER, OVERSIZED, M6, 18-8 STAINLESS	3
4	NS-HARDWARE	SCREW, BUTTON HEAD, M6-1.0 X 25mm	3
5	NS-HARDWARE	WASHER, SPLIT LOCK, M6, 18-8 STAINLESS	3

2.4 VP-180SC-24HVC.2 – ASSY, V-PLATE VACUUM TESTER, SELF CONTAINED, 24”, 220V, HI-VAC (Parts List)

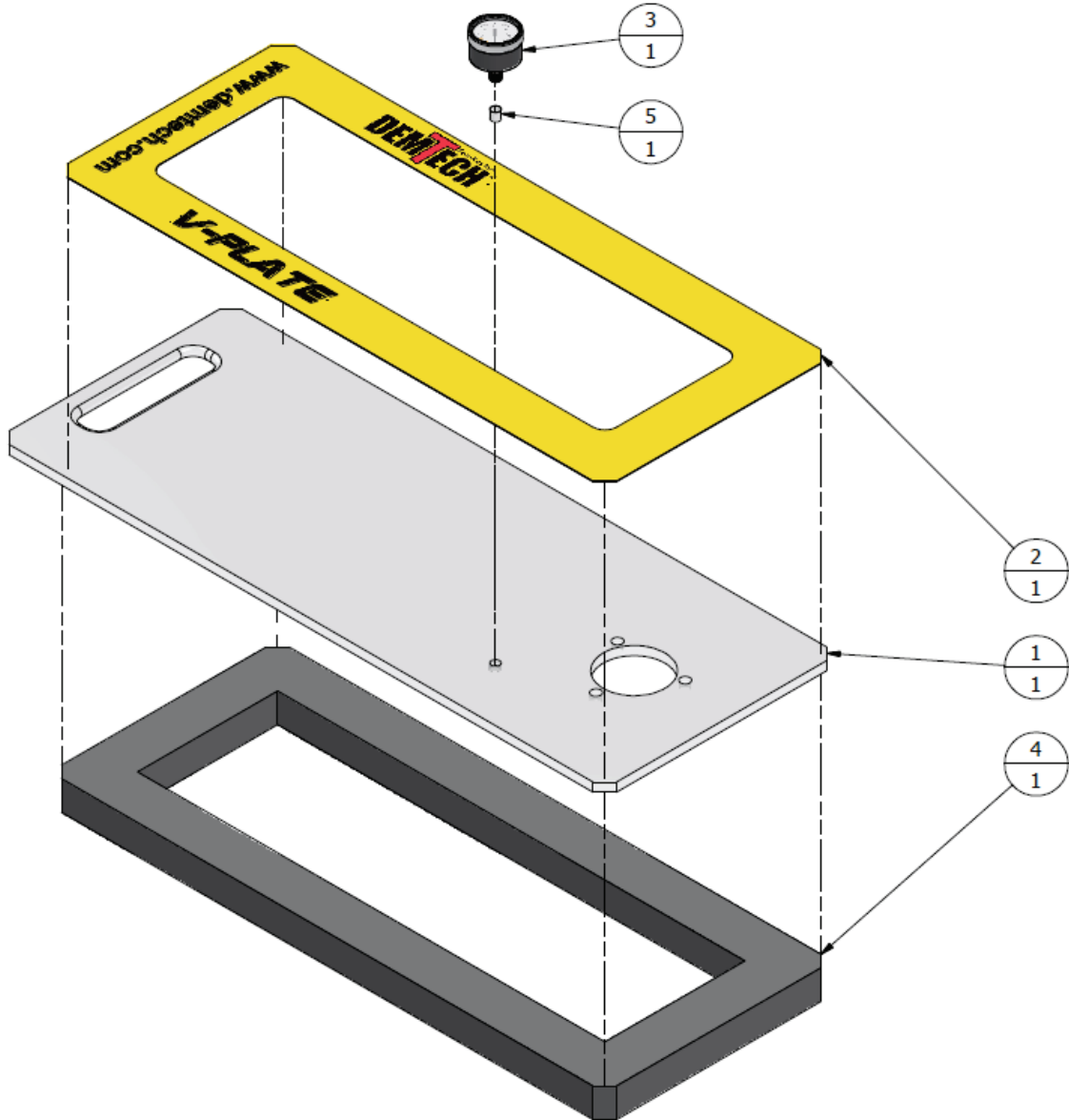

2.5 VP-180SC-24HVC.1 – ASSY, V-PLATE VACUUM TESTER, SELF CONTAINED, 24”, HI-VAC, W/O MOTOR (Parts ID)



PARTS LIST			
REF. NO	PART NO	DESCRIPTION	QTY
1	VP-180SC-24.2	SIGHT PLATE, SELF-CONTAINED, 24" FLAT, (180°)	1
2	VP-24-OL	OVERLAY, VP 24" ADHESIVE	1
3	VP-210G	GAUGE, 1-1/2" DIAL, VACUUM 0-30" Hg, 1/8" NPT, CENTER BACK MOUNT	1
4	VP-181-24	GASKET, V-PLATE, FLAT, 24"	1
5	STOCK	THREAD SEAL TAPE, PTFE, .25" WIDE	1

2.6 VP-180SC-24HVC.1 – ASSY, V-PLATE VACUUM TESTER, SELF CONTAINED, 24”, HI-VAC, W/O MOTOR (Parts List)

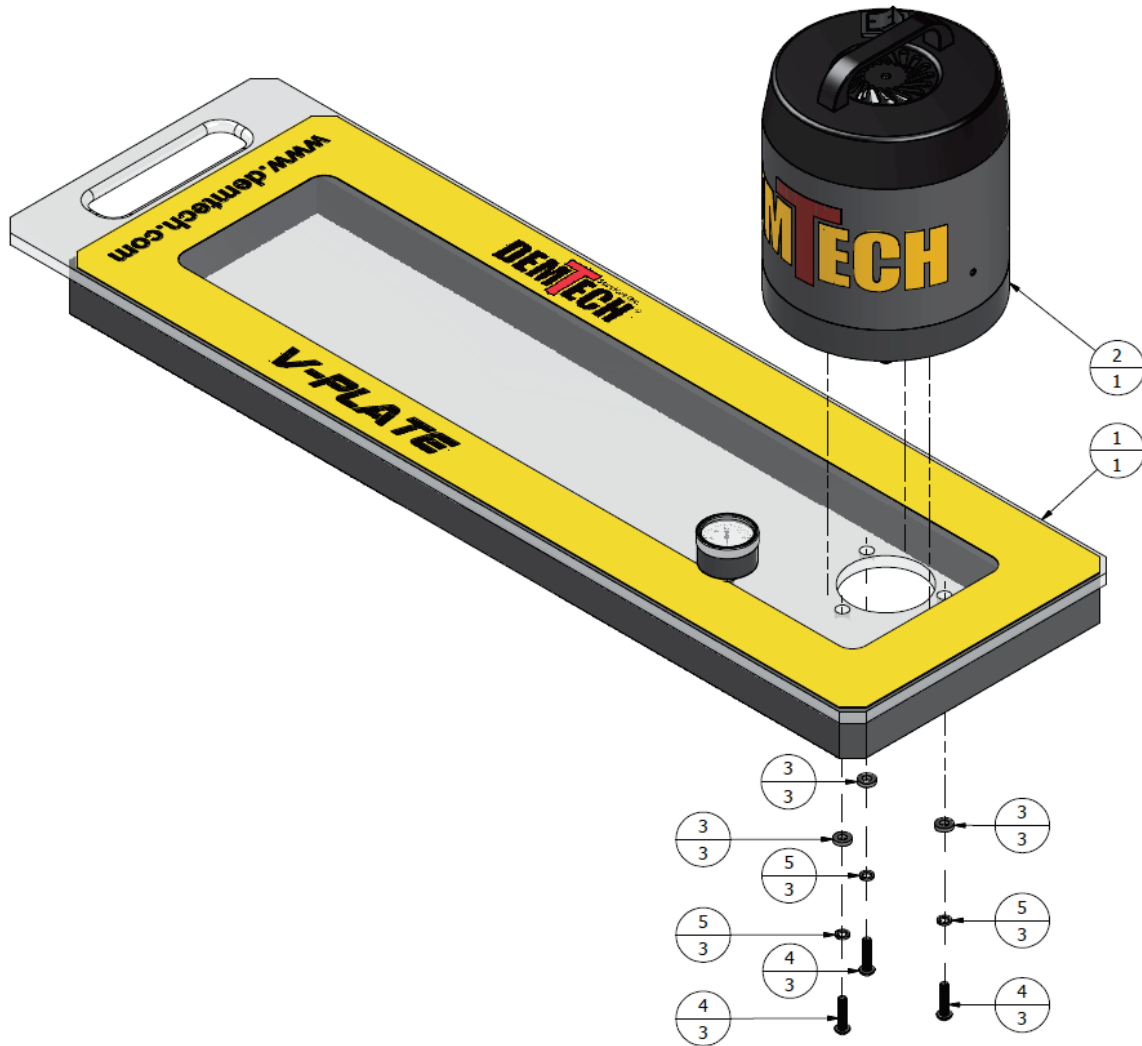

2.7 VP-180SC-30HVC – ASSY, V-PLATE VACUUM TESTER, SELF-CONTAINED, 30”, 110V, HI-VAC (Parts ID)



PARTS LIST			
REF. NO	PART NUMBER	DESCRIPTION	QTY
1	VP-180SC-30HVC.1	ASSY, PLATE, VACUUM, 30", W/O MOTOR	1
2	VP-225HV/A	ASSEMBLY, VACUUM MOTOR, 110V, HI-VAC	1
3	NS-HARDWARE	WASHER, OVERSIZED, M6, 18-8 STAINLESS	3
4	NS-HARDWARE	SCREW, BUTTON HEAD, M6-1.0 X 25mm	3
5	NS-HARDWARE	WASHER, SPLIT LOCK, M6, 18-8 STAINLESS	3

2.8 VP-180SC-30HVC – ASSY, V-PLATE VACUUM TESTER, SELF-CONTAINED, 30”, 110V, HI-VAC (Parts List)

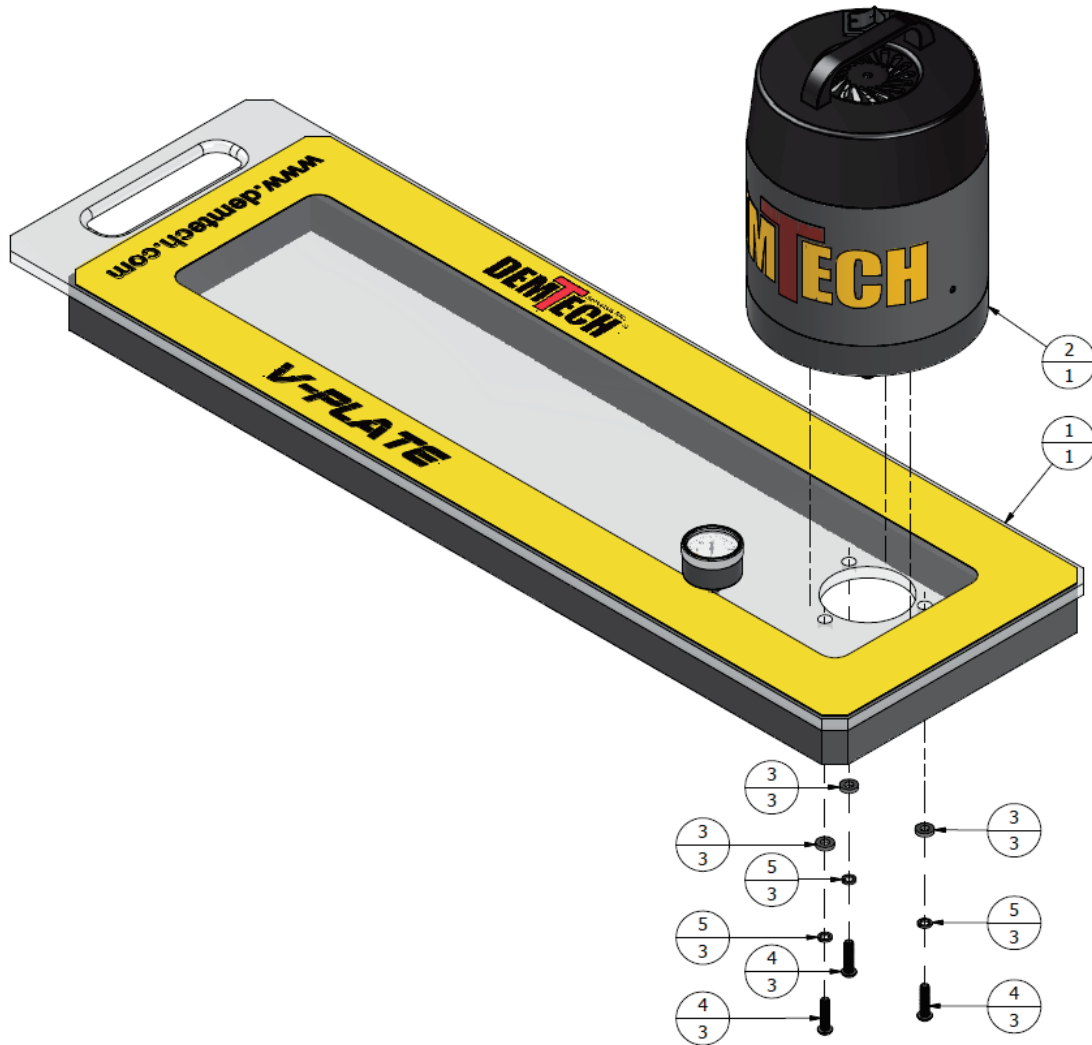

2.9 VP-180SC-30HVC.2 – ASSY, V-PLATE VACUUM TESTER, SELF-CONTAINED, 30”, 220V, HI-VAC (Parts ID)



PARTS LIST			
REF. NO	PART NUMBER	DESCRIPTION	QTY
1	VP-180SC-30HVC.1	ASSY, PLATE, VACUUM, 30", W/O MOTOR	1
2	VP-220HV.2/A	ASSEMBLY, VACUUM MOTOR, 220V, HI-VAC	1
3	NS-HARDWARE	WASHER, OVERSIZED, M6, 18-8 STAINLESS	3
4	NS-HARDWARE	SCREW, BUTTON HEAD, M6-1.0 X 25mm	3
5	NS-HARDWARE	WASHER, SPLIT LOCK, M6, 18-8 STAINLESS	3

2.10 VP-180SC-30HVC.2 – ASSY, V-PLATE VACUUM TESTER, SELF-CONTAINED, 30”, 220V, HI-VAC (Parts List)

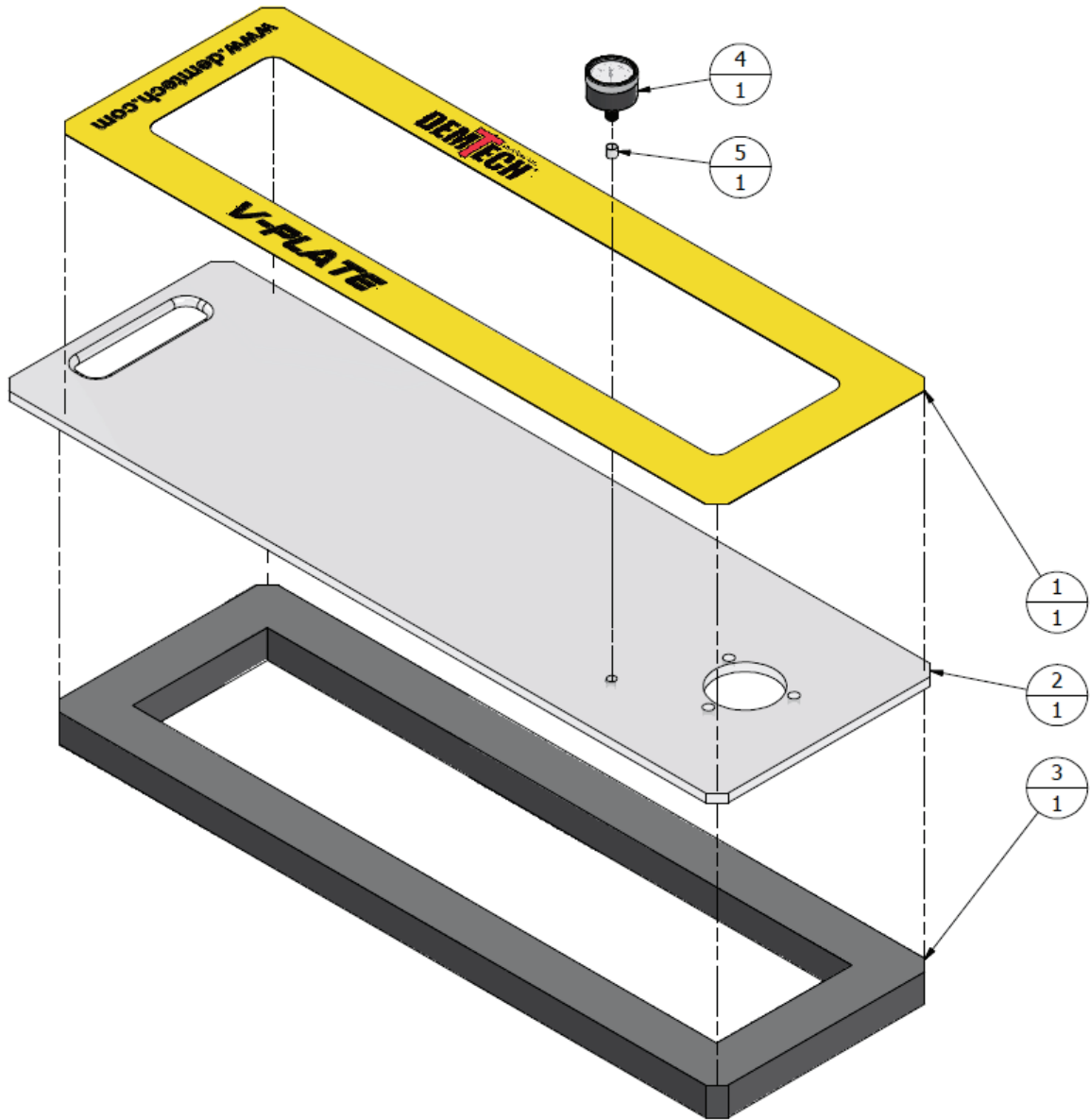

2.11 VP-180SC-30HVC.1 – ASSY, PLATE, VACUUM, 30”, W/O MOTOR (Parts ID)



REF. NO	PART NO	DESCRIPTION	QTY
1	VP-30-OL	OVERLAY, VP 30" ADHESIVE	1
2	VP-180SC-30.2	SIGHT PLATE, SELF-CONTAINED, 30" FLAT, (180°)	1
3	VP-181-30	GASKET, V-PLATE, FLAT, 30"	1
4	VP-210G	GAUGE, 1-1/2" DIAL, VACUUM 0-30" Hg, 1/8" NPT, CENTER BACK MOUNT	1
5	STOCK	THREAD SEAL TAPE, PTFE, .25" WIDE	1

2.12 VP-180SC-30HVC.1 – ASSY, PLATE, VACUUM, 30”, W/O MOTOR (Parts List)

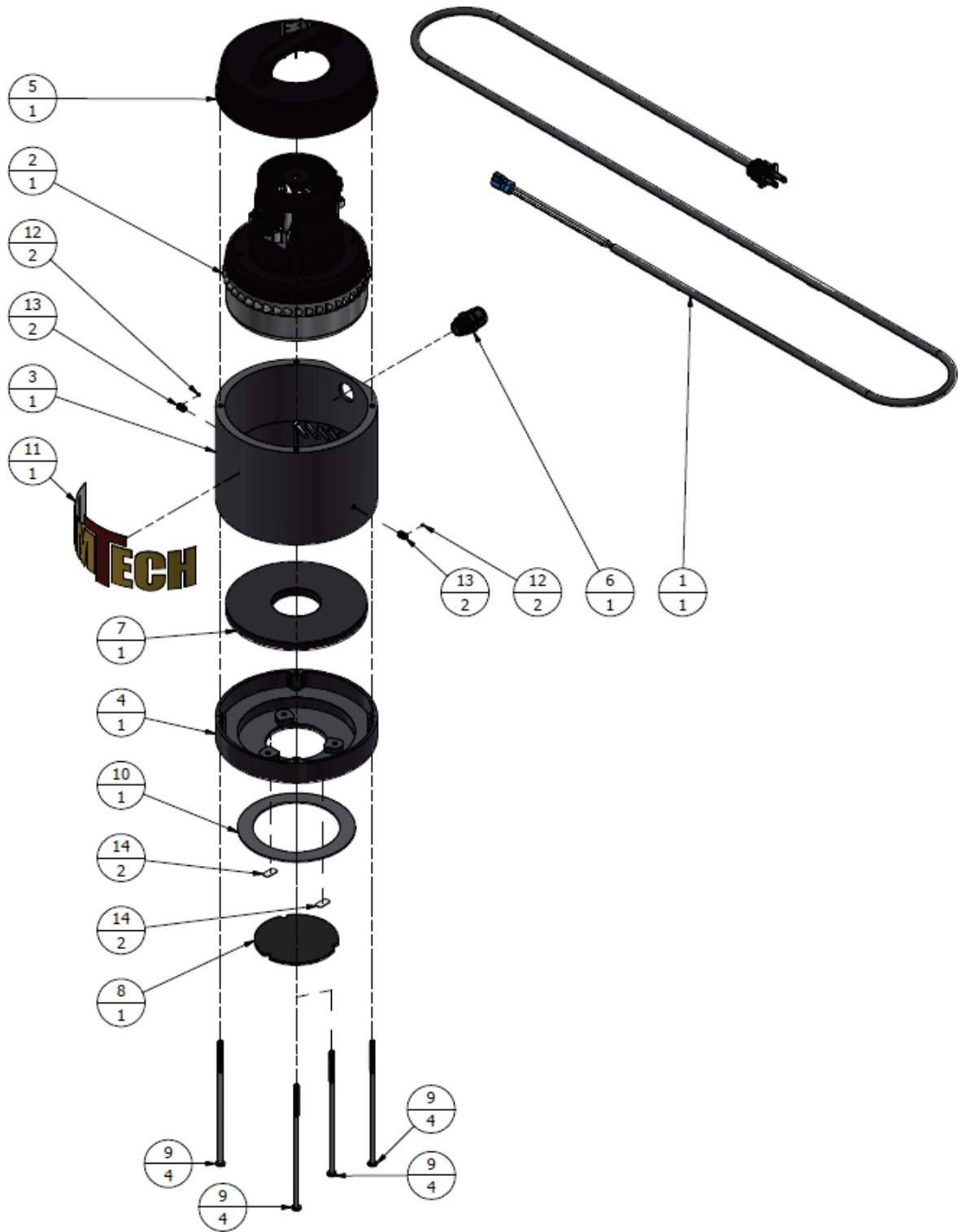

2.13 VP-225HV/A – ASSY, VACUUM MOTOR, 110V, HI-VAC (Parts ID)



PARTS LIST			
REF. NO	PART NUMBER	DESCRIPTION	QTY
1	DT-POW-CRD	POWER CORD, 120V, 2 BLADE, 5' LONG	1
2	VP-225HV	MOTOR, VACUUM, 110V, HI-VAC	1
3	VP-230HV	HOUSING, MOTOR, HI-VAC	1
4	VP-235HV	FLANGE, MOTOR MOUNT, HI-VAC	1
5	VP-240HV/A	ASSEMBLY, LID, VACUUM MOTOR, 110V, HI-VAC	1
6	VP-250HV	STRAIN RELIEF, POWER CORD, HI-VAC	1
7	VP-255HV	GASKET, MOTOR, HI-VAC	1
8	VP-260HV	FILTER, PARTICULAE, HI-VAC MOTOR	1
9	VP-270HV	SCREW, MOUNTING, 6", HI-VAC	4
10	VP-275HV	GASKET, MOTOR HOUSING, HI-VAC	1
11	VP-LABELHV	LABEL, DEMTECH, HI-VAC	1
12	NS-HARDWARE	ADHESIVE, THREADLOCKING LIQUID, BLUE, FOR PLASTICS	2
13	NS-HARDWARE	SCREW, SET, M6-1.0 X 10mm LONG, CUP POINT ALLEN, 18-8 STAINLESS STEEL	2
14	NS-HARDWARE	SEALANT, ALL PURPOSE, 100% SILICONE, CLEAR	2

2.14 VP-225HV/A – ASSY, VACUUM MOTOR, 110V, HI-VAC (Parts List)

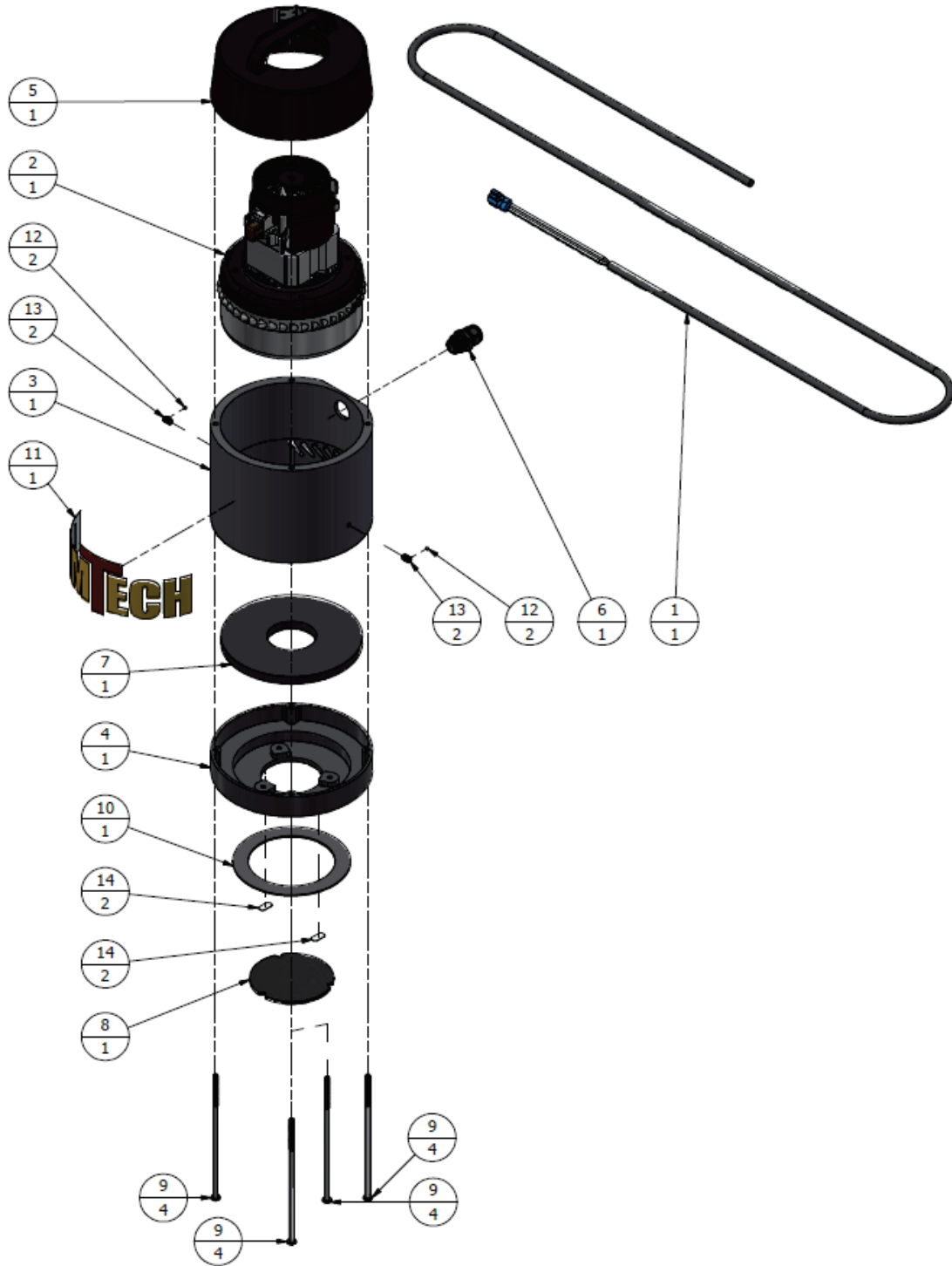

2.15 VP-220HV.2/A – ASSY, VACUUM MOTOR, 220V, HI-VAC (Parts ID)



PARTS LIST			
REF. NO	PART NUMBER	DESCRIPTION	QTY
1	DT-POW-CRD	POWER CORD, 220V, PLUG BY REQUEST, 5' LONG	1
2	VP-220HV.2	MOTOR, VACUUM, 220V, HI-VAC	1
3	VP-230HV	HOUSING, MOTOR, HI-VAC	1
4	VP-235HV	FLANGE, MOTOR MOUNT, HI-VAC	1
5	VP-240HV.2/A	ASSEMBLY, LID, VACUUM MOTOR, 220V, HI-VAC	1
6	VP-250HV	STRAIN RELIEF, POWER CORD, HI-VAC	1
7	VP-255HV	GASKET, MOTOR, HI-VAC	1
8	VP-260HV	FILTER, PARTICULAE, HI-VAC MOTOR	1
9	VP-270HV	SCREW, MOUNTING, 6", HI-VAC	4
10	VP-275HV	GASKET, MOTOR HOUSING, HI-VAC	1
11	VP-LABELHV	LABEL, DEMTECH, HI-VAC	1
12	NS-HARDWARE	ADHESIVE, THREADLOCKING LIQUID, BLUE, FOR PLASTICS	2
13	NS-HARDWARE	SCREW, SET, M6-1.0 X 10mm LONG, CUP POINT ALLEN, 18-8 STAINLESS STEEL	2
14	NS-HARDWARE	ADHESIVE, CONSTRUCTION, CLEAR, FILTER MEDIUM	2

2.16 VP-220HV.2/A – ASSY, MOTOR, 220V, HI-VAC (Parts List)

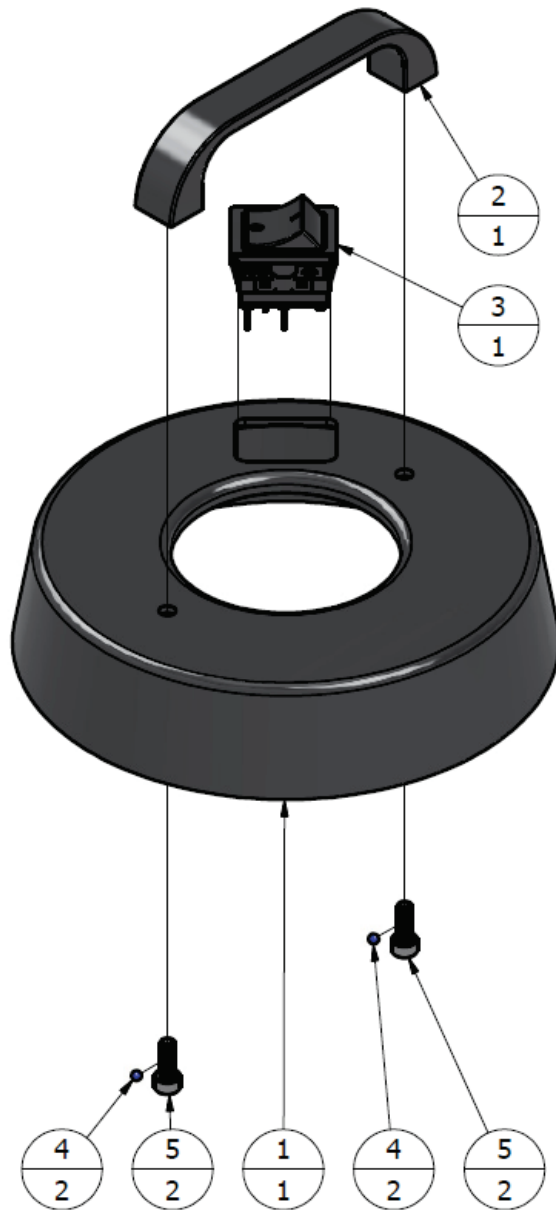

**2.17 VP-240HV/A – ASSY, LID, VACUUM MOTOR, 110V, HI-VAC
(Parts ID)**



PARTS LIST			
REF. NO	PART NUMBER	DESCRIPTION	QTY
1	VP-240HV	LID, MOTOR, 110V, HI-VAC	1
2	VP-265HV	HANDLE, COVER, HI-VAC	1
3	VP-285HV	SWITCH, ROCKER, SEALED, 16A, 125VAC, IP66 RATED	1
4	NS-HARDWARE	ADHESIVE, THREADLOCKING LIQUID, BLUE	2
5	NS-HARDWARE	SCREW, 10-24 X 1/2" LONG, SOCKET HEAD CAP, 18-8 STAINLESS STEEL	2

**2.18 VP-240HV/A – ASSY, LID, VACUUM MOTOR, 110V, HI-VAC
(Parts List)**

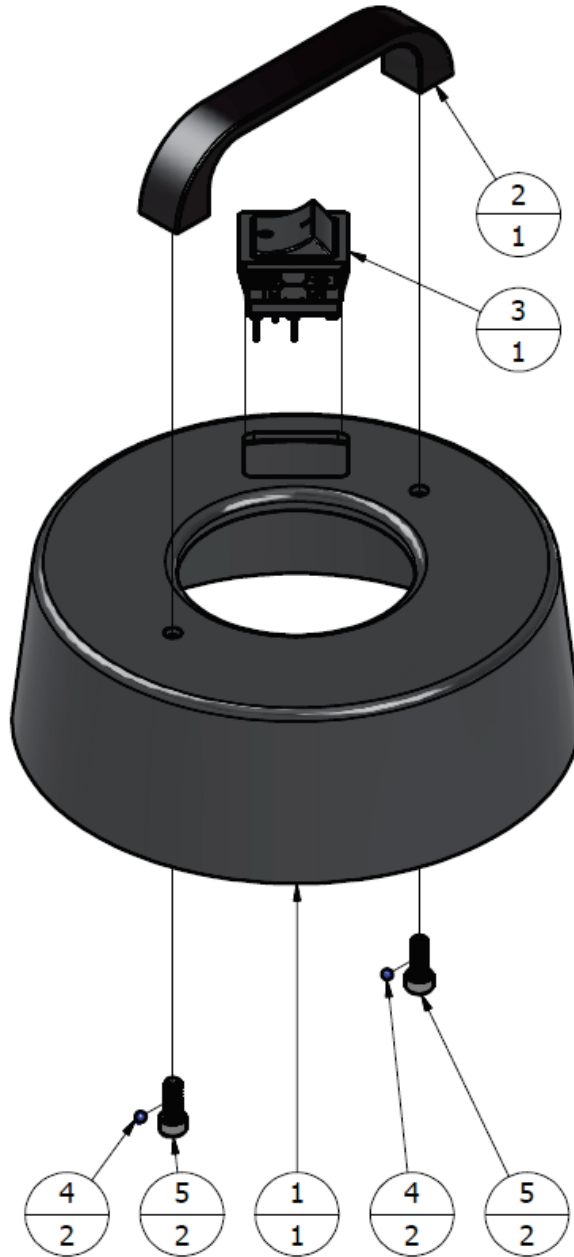

**2.19 VP-240HV.2/A – ASSY, LID, VACUUM MOTOR, 220V, HI-VAC
(Parts ID)**



PARTS LIST			
REF. NO	PART NUMBER	DESCRIPTION	QTY
1	VP-240HV.2	LID, MOTOR, 220V, HI-VAC	1
2	VP-265HV	HANDLE, COVER, HI-VAC	1
3	VP-285HV	SWITCH, ROCKER, SEALED, 16A, 125VAC, IP66 RATED	1
4	NS-HARDWARE	ADHESIVE, THREADLOCKING LIQUID, BLUE	2
5	NS-HARDWARE	SCREW, 10-24 X 1/2" LONG, SOCKET HEAD CAP, 18-8 STAINLESS STEEL	2

***2.20 VP-240HV.2/A – ASSY, LID, VACUUM MOTOR, 220V, HI-VAC
(Parts List)***

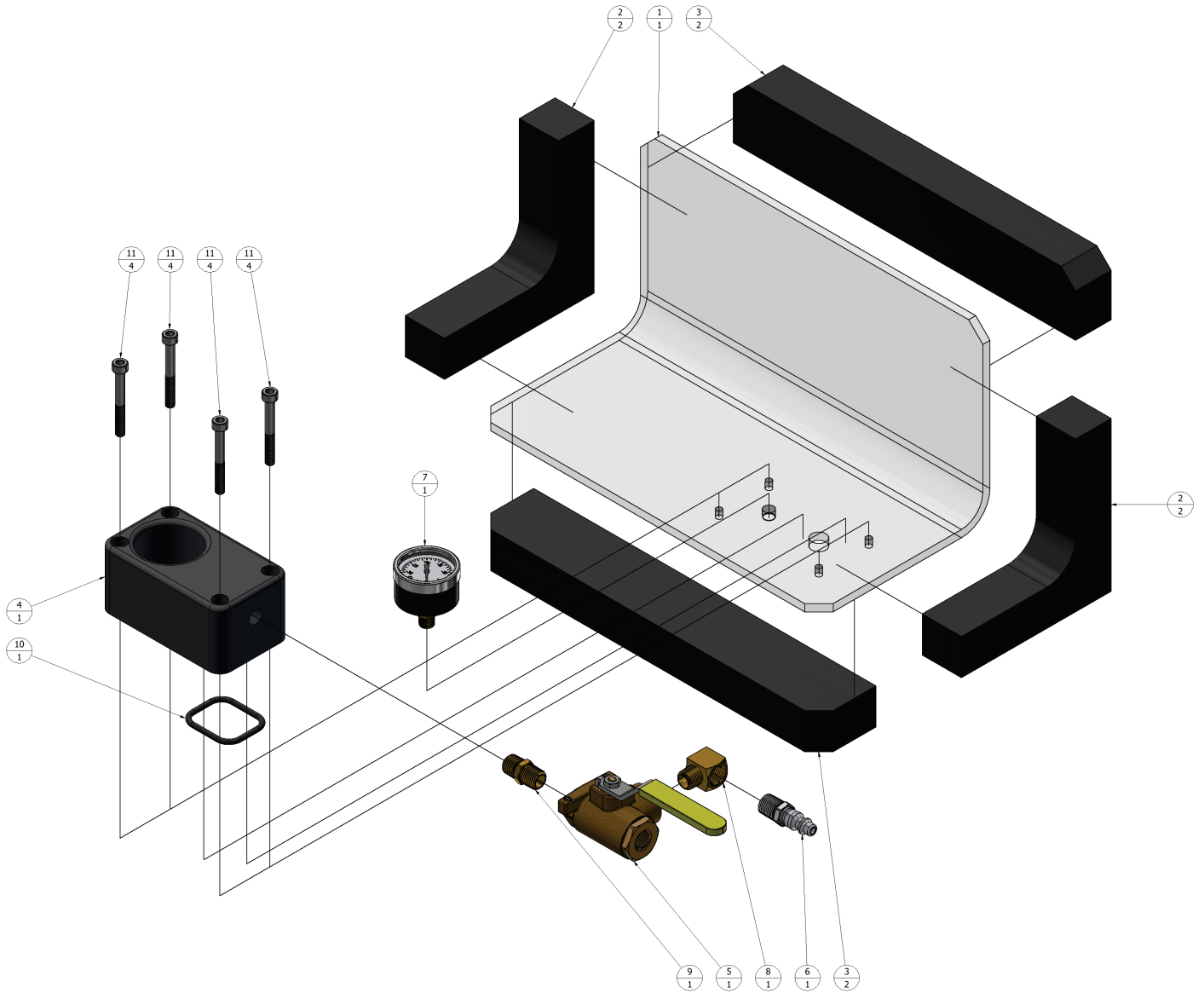

**2.21 VP-90-12C - ASSY, V-PLATE TESTING SYSTEM, 12" X 90°
(Parts ID)**



PARTS LIST			
REF. NO	PART NO	DESCRIPTION	QTY
1	VP-90-12	SIGHT PLATE, ANGLED, 12" X 90°	1
2	VP-91	GASKET, END, ANGLED PLATE	2
3	VP-92-12	GASKET, STRAIGHT, ANGLED PLATE, 12"	2
4	VP-200	BLOCK, VACUUM CHAMBER, MANIFOLD	1
5	VP-201	VALVE, 3-WAY BALL, VACUUM CONTROL	1
6	VP-203.1	FITTING, QUICK CONNECT, MALE, 1/4" NPT MALE	1
7	VP-210G	GAUGE, 1-1/2" DIAL, VACUUM 0-30" Hg, 1/8" NPT, CENTER BACK MOUNT	1
8	VP-216	FITTING, 90° ELBOW, 1/4" NPT MALE/FEMALE	1
9	VP-217	FITTING, HEX NIPPLE, 1/4" MALE NPT	1
10	NS-HARDWARE	O-RING, AS568A-223, 1-5/8" ID X 1/8" CS, 70 SHORE A, BLACK BUNA-N	1
11	NS-HARDWARE	SCREW, M6-1.0 X 50mm LONG, SOCKET HEAD CAP, 18-8 STAINLESS STEEL	4

***2.22 VP-90-12C - ASSY, V-PLATE TESTING SYSTEM, 12" X 90°
(Parts List)***

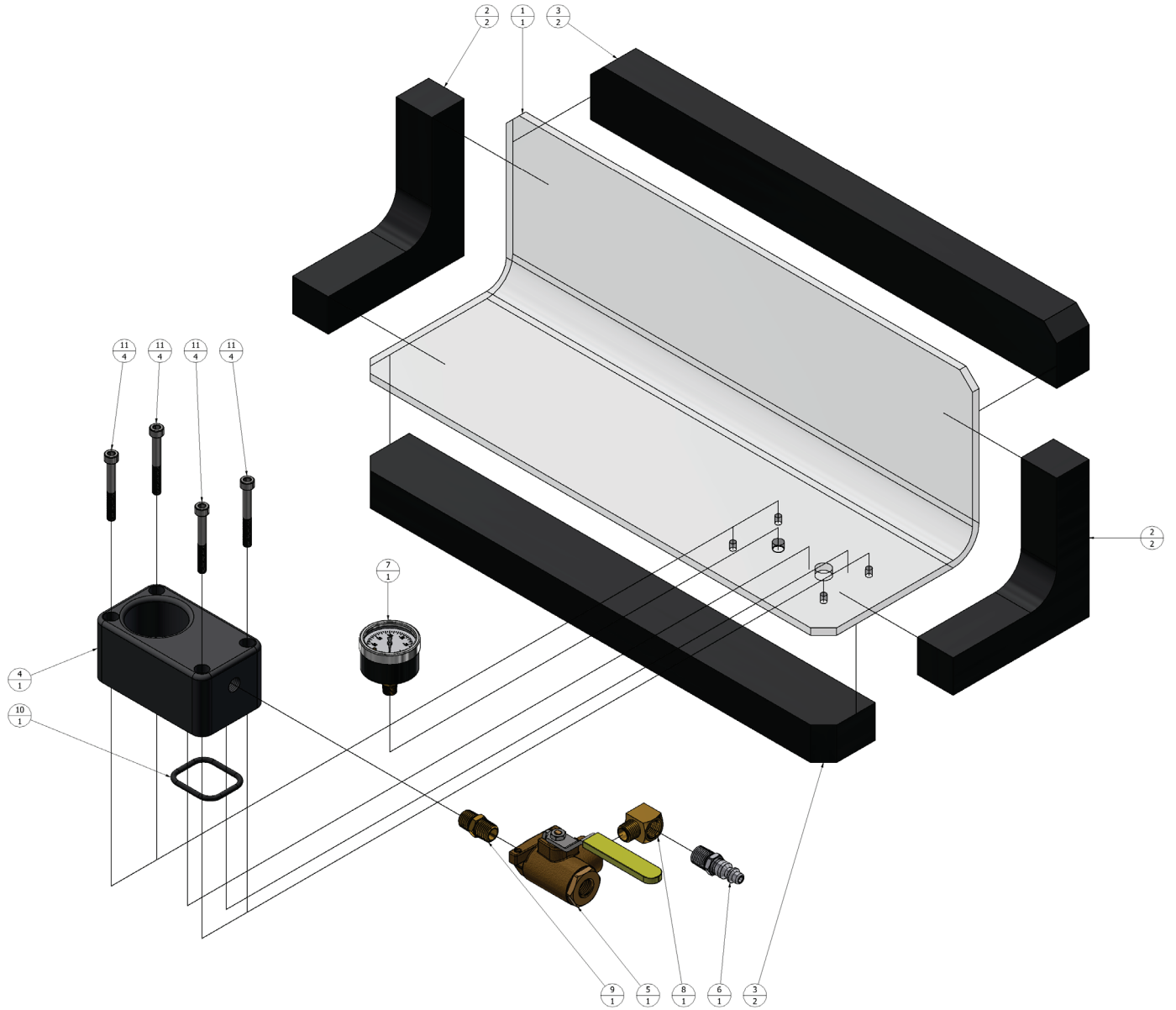

**2.23 VP-90-18C – ASSY, V-PLATE TESTING SYSTEM, 18” X 90°
(Parts ID)**



PARTS LIST			
REF. NO	PART NO	DESCRIPTION	QTY
1	VP-90-18	SIGHT PLATE, ANGLED, 18" X 90°	1
2	VP-91	GASKET, END, ANGLED PLATE	2
3	VP-92-18	GASKET, STRAIGHT, ANGLED PLATE, 18"	2
4	VP-200	BLOCK, VACUUM CHAMBER, MANIFOLD	1
5	VP-201	VALVE, 3-WAY BALL, VACUUM CONTROL	1
6	VP-203.1	FITTING, QUICK CONNECT, MALE, 1/4" NPT MALE	1
7	VP-210G	GAUGE, 1-1/2" DIAL, VACUUM 0-30" Hg, 1/8" NPT, CENTER BACK MOUNT	1
8	VP-216	FITTING, 90° ELBOW, 1/4" NPT MALE/FEMALE	1
9	VP-217	FITTING, HEX NIPPLE, 1/4" MALE NPT	1
10	NS-HARDWARE	O-RING, AS568A-223, 1-5/8" ID X 1/8" CS, 70 SHORE A, BLACK BUNA-N	1
11	NS-HARDWARE	SCREW, M6-1.0 X 50mm LONG, SOCKET HEAD CAP, 18-8 STAINLESS STEEL	4

***2.24 VP-90-18C – ASSY, V-PLATE TESTING SYSTEM, 18" X 90°
(Parts List)***

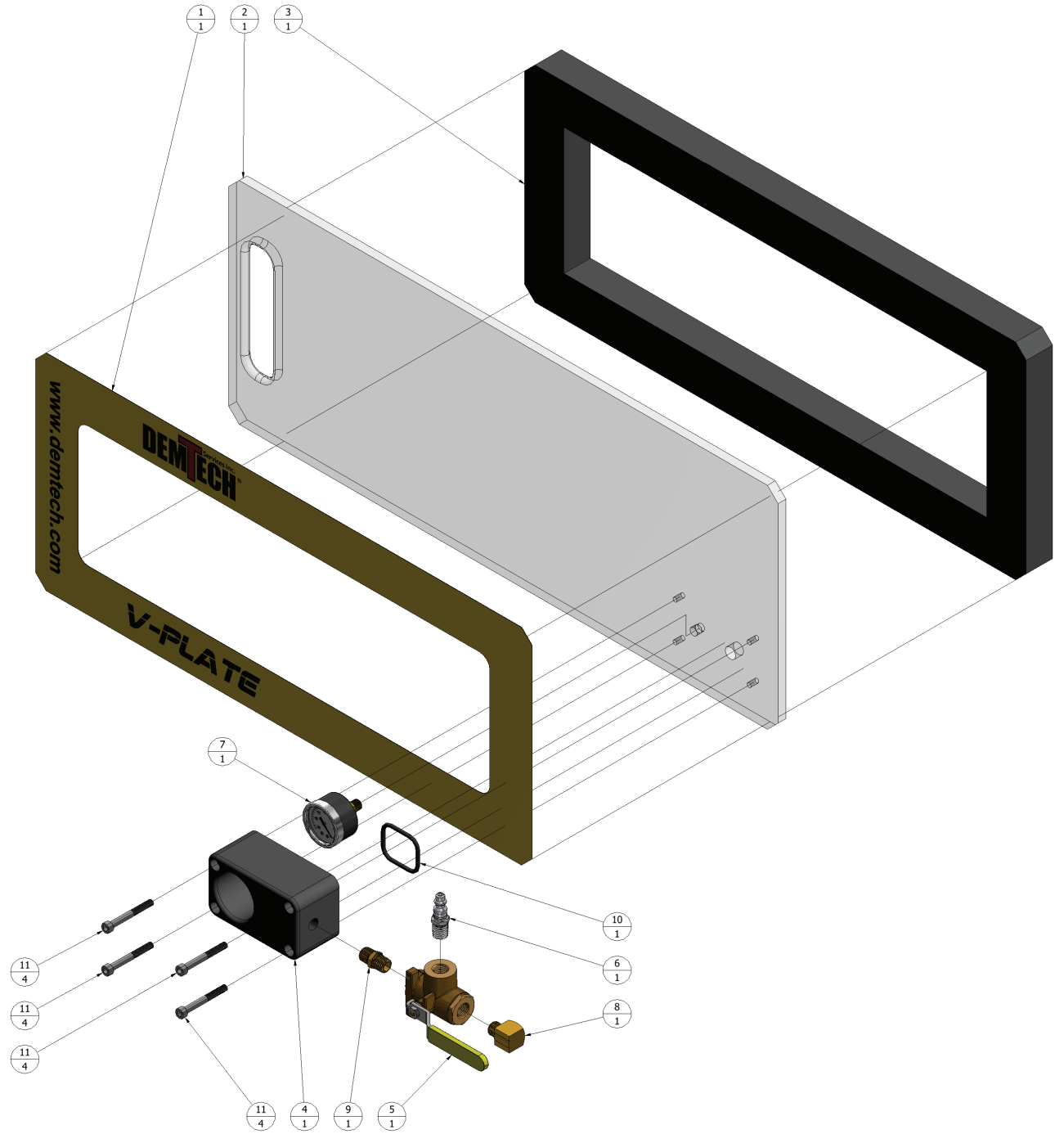

2.25 VP-180-24C – ASSY, V-PLATE VACUUM TESTER, 24”, FLAT, NON SELF-CONTAINED (Parts ID)



PARTS LIST			
REF. NO	PART NO	DESCRIPTION	QTY
1	VP-24-OL	OVERLAY, VP 24" ADHESIVE	1
2	VP-180-24	SIGHT PLATE, NON SELF CONTAINED, 10" X 24"	1
3	VP-181-24	GASKET, V-PLATE, FLAT, 24"	1
4	VP-200	BLOCK, VACUUM CHAMBER, MANIFOLD	1
5	VP-201	VALVE, 3-WAY BALL, VACUUM CONTROL	1
6	VP-203.1	FITTING, QUICK CONNECT, MALE, 1/4" NPT MALE	1
7	VP-210G	GAUGE, 1-1/2" DIAL, VACUUM 0-30" Hg, 1/8" NPT, CENTER BACK MOUNT	1
8	VP-216	FITTING, 90° ELBOW, 1/4" NPT MALE/FEMALE	1
9	VP-217	FITTING, HEX NIPPLE, 1/4" MALE NPT	1
10	NS-HARDWARE	O-RING, AS568A-223, 1-5/8" ID X 1/8" CS, 70 SHORE A, BLACK BUNA-N	1
11	NS-HARDWARE	SCREW, M6-1.0 X 50mm LONG, SOCKET HEAD CAP, 18-8 STAINLESS STEEL	4

2.26 VP-180-24C – ASSY, V-PLATE VACUUM TESTER, 24”, FLAT, NON SELF-CONTAINED (Parts List)

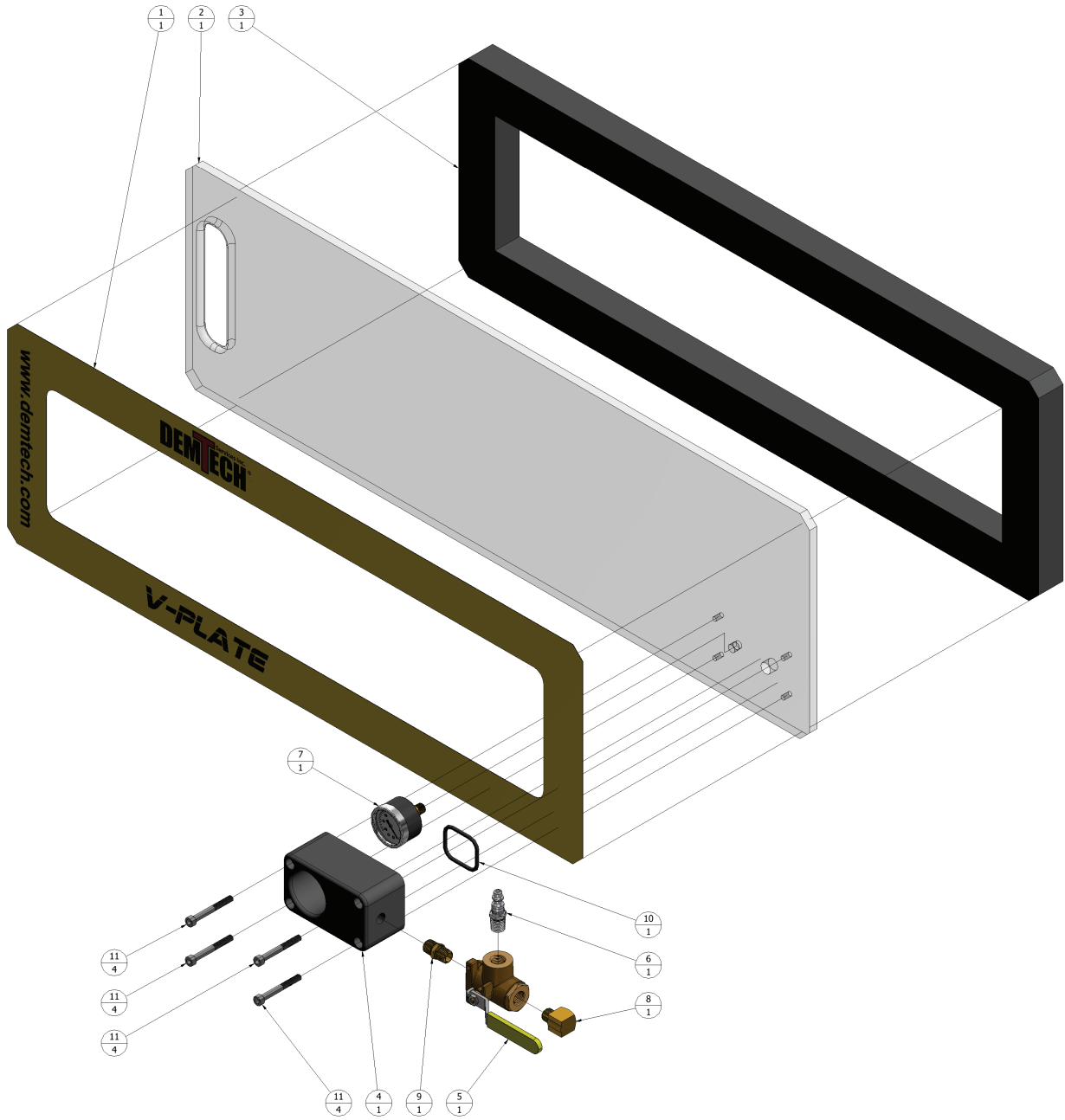

**2.27 VP-180-30C – ASSY, V-PLATE VACUUM TESTER, 30” FLAT,
NON SELF-CONTAINED (Parts ID)**



PARTS LIST			
REF. NO	PART NO	DESCRIPTION	QTY
1	VP-30-OL	OVERLAY, VP 30" ADHESIVE	1
2	VP-180-30	SIGHT PLATE, NON SELF CONTAINED, 10" X 30"	1
3	VP-181-30	GASKET, V-PLATE, FLAT, 30"	1
4	VP-200	BLOCK, VACUUM CHAMBER, MANIFOLD	1
5	VP-201	VALVE, 3-WAY BALL, VACUUM CONTROL	1
6	VP-203.1	FITTING, QUICK CONNECT, MALE, 1/4" NPT MALE	1
7	VP-210G	GAUGE, 1-1/2" DIAL, VACUUM 0-30" Hg, 1/8" NPT, CENTER BACK MOUNT	1
8	VP-216	FITTING, 90° ELBOW, 1/4" NPT MALE/FEMALE	1
9	VP-217	FITTING, HEX NIPPLE, 1/4" MALE NPT	1
10	NS-HARDWARE	O-RING, AS568A-223, 1-5/8" ID X 1/8" CS, 70 SHORE A, BLACK BUNA-N	1
11	NS-HARDWARE	SCREW, M6-1.0 X 50mm LONG, SOCKET HEAD CAP, 18-8 STAINLESS STEEL	4

**2.28 VP-180-30C – ASSY, V-PLATE VACUUM TESTER, 30" FLAT,
NON SELF-CONTAINED (Parts List)**