

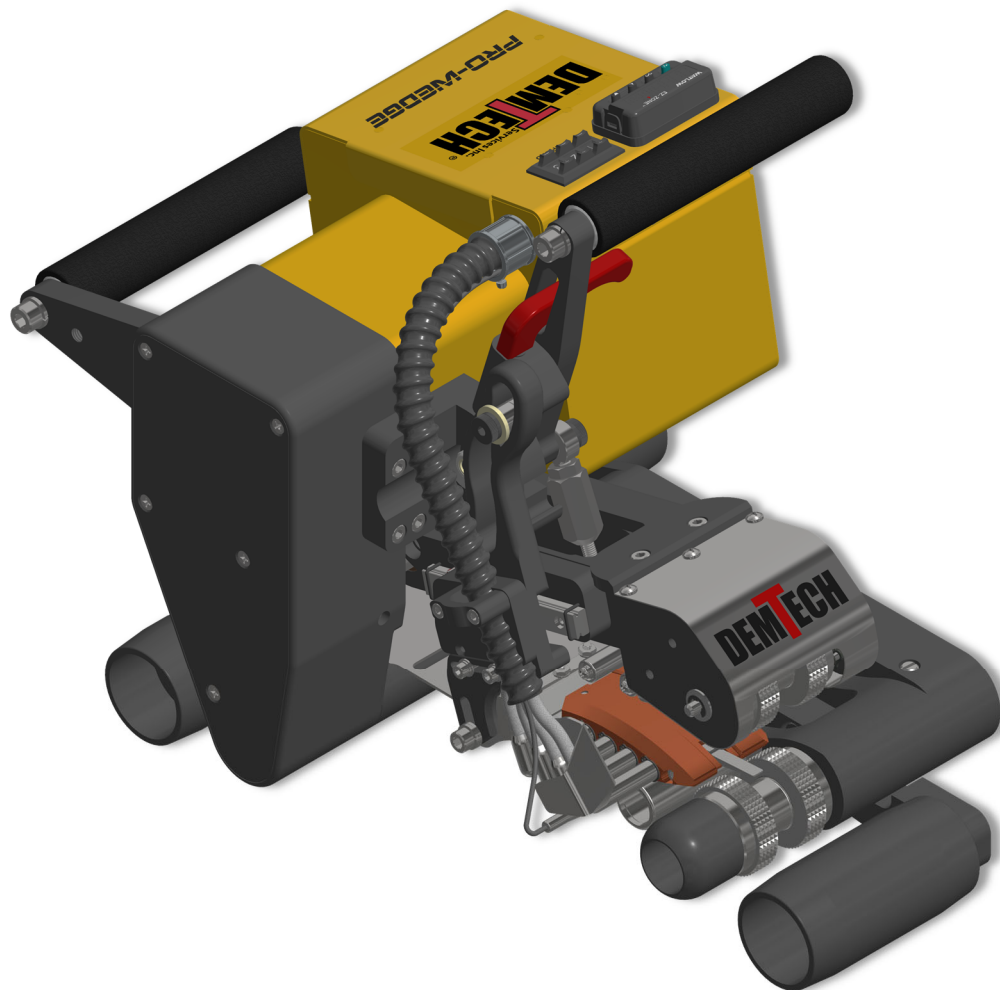

Pro-Wedge

W/ Auto-Engage



Parts ID Manual

Model Number: ProWedgeAU/A

Revision: E

© Copyright 2024 by DEMTECH Services, Inc.

All Rights Reserved

Scope of Manual:

This manual contains diagrams and related parts lists to identify potential service/spare parts for your DEMTECH Services, Inc. Pro-Wedge.

The text of this publication, or any part thereof, may not be reproduced or transmitted in any form or by any means, electronic or mechanical, including photocopying, recording, storage in an information retrieval system, or otherwise, without prior written permission of DEMTECH Services, Inc.

Notice

Patents have been granted and/or patent applications are pending or are in the process of preparation on all DEMTECH Services, Inc. developments.

The material in the manual is for informational purposes only and is subject to change without notice.

DEMTECH Services, Inc. assumes no responsibility for any errors that may appear in this manual.

DEMTECH Services, Inc.
6414 Capitol Avenue Diamond Springs, CA 95619 U.S.A.
Telephone: (530) 621-3200
Toll Free: (888) 324-9353
Web Site: www.demtech.com

TABLE OF CONTENTS

1	ORDER INSTRUCTIONS.....	PAGE 1
1.1	ProWedgeAU/A – ASSY, 2” WEDGE WELDER (Parts ID).....	Page 2
1.2	ProWedgeAU/A – ASSY, 2” WEDGE WELDER (Parts List).....	Page 3
1.3	ProWedgeAU/A – ASSY, 2” WEDGE WELDER CONTD. (Parts List).....	Page 4
1.4	100-200AU/KIT/A - ASSY, AUTO ENGAGE KIT (Parts ID).....	Page 5
1.5	100-200AU/KIT/A - ASSY, AUTO ENGAGE KIT (Parts List).....	Page 6
1.6	100-225W/A – ASSY, REAR TRAVEL ROLLER, WIDE (Parts ID).....	Page 7
1.7	100-225/A – ASSY, FRONT TRAVEL ROLLER (Parts ID).....	Page 7
1.8	100-225W/A – ASSY, REAR TRAVEL ROLLER, WIDE (Parts List).....	Page 8
1.9	100-225/A – ASSY, FRONT TRAVEL ROLLER (Parts List).....	Page 8
1.10	100-016/A – ASSY, CONTROL BOX, 110V (Parts ID).....	Page 9
1.11	100-016/A – ASSY, CONTROL BOX, 110V (Parts List).....	Page 10
1.12	100-017/A – ASSY, CONTROL PANEL, 120V (Parts ID).....	Page 11
1.13	100-017/A – ASSY, CONTROL PANEL, 120V (Parts List).....	Page 12
1.14	100-160A/A ASSY, 3/4” (45mm) COPPER, DUAL TRACK, 110V (Parts ID).....	Page 13
1.15	100-160A/A – ASSY, 2” (50mm) WEDGE, SOLID, COPPER, 110V (Parts List).....	Page 14
1.16	100-16XXXX – ASSEMBLED WEDGE OPTIONS (Parts ID).....	Page 15
1.17	100-16XXXX – ASSEMBLED WEDGE OPTIONS (Parts List).....	Page 16
1.18	100-180/A – ASSY, LOWER FRAME (Parts ID).....	Page 17
1.19	100-180/A – ASSY, LOWER FRAME (Parts List).....	Page 18
1.20	100-185/A – ASSY, SIDE FRAME (Parts ID).....	Page 19
1.21	100-185/A – ASSY, SIDE FRAME (Parts List).....	Page 20

TABLE OF CONTENTS CONTD.

1.22 100-190/A – ASSY, UPPER NIP ARM (Parts ID).....	Page 21
1.23 100-190/A – ASSY, UPPER NIP ARM (Parts List).....	Page 22
1.24 100-191/A.1, .2, .3, and .4 – ASSY, UPPER CONTOUR ROLLER (Parts ID).....	Page 23
1.25 100-191/A.1, .2, .3, and .4 – ASSY, UPPER CONTOUR ROLLER (Parts List).....	Page 24
1.26 100-191N/A - ASSY, UPPER CONTOUR ROLLER AXLE.....	Page 25
1.27 100-191N/A - ASSY, UPPER CONTOUR ROLLER AXLE.....	Page 26
1.28 100-15XXXX – NIP ROLLERS, Parts ID & Parts List.....	Page 27

1 Order Instructions

Refer to the diagrams and related parts lists on the following pages to identify potential service/spare parts for the Pro-Wedge. To locate a part, find it visually on the exploded assembly diagram and note its Reference Number. Next refer to the assemblies parts list to identify the corresponding Part Number using the Reference Number. When ordering parts, be sure to specify the Part Number not the Reference Number. '*NS-Hardware*' refers to non-stock items, these parts are still available for order, please provide the part description to order NS-Hardware items.

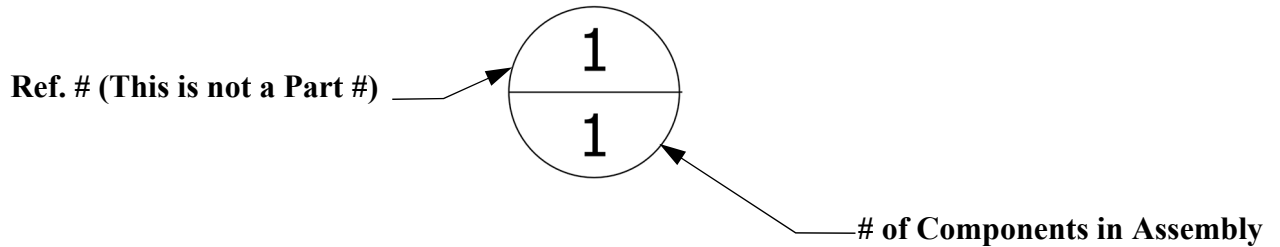

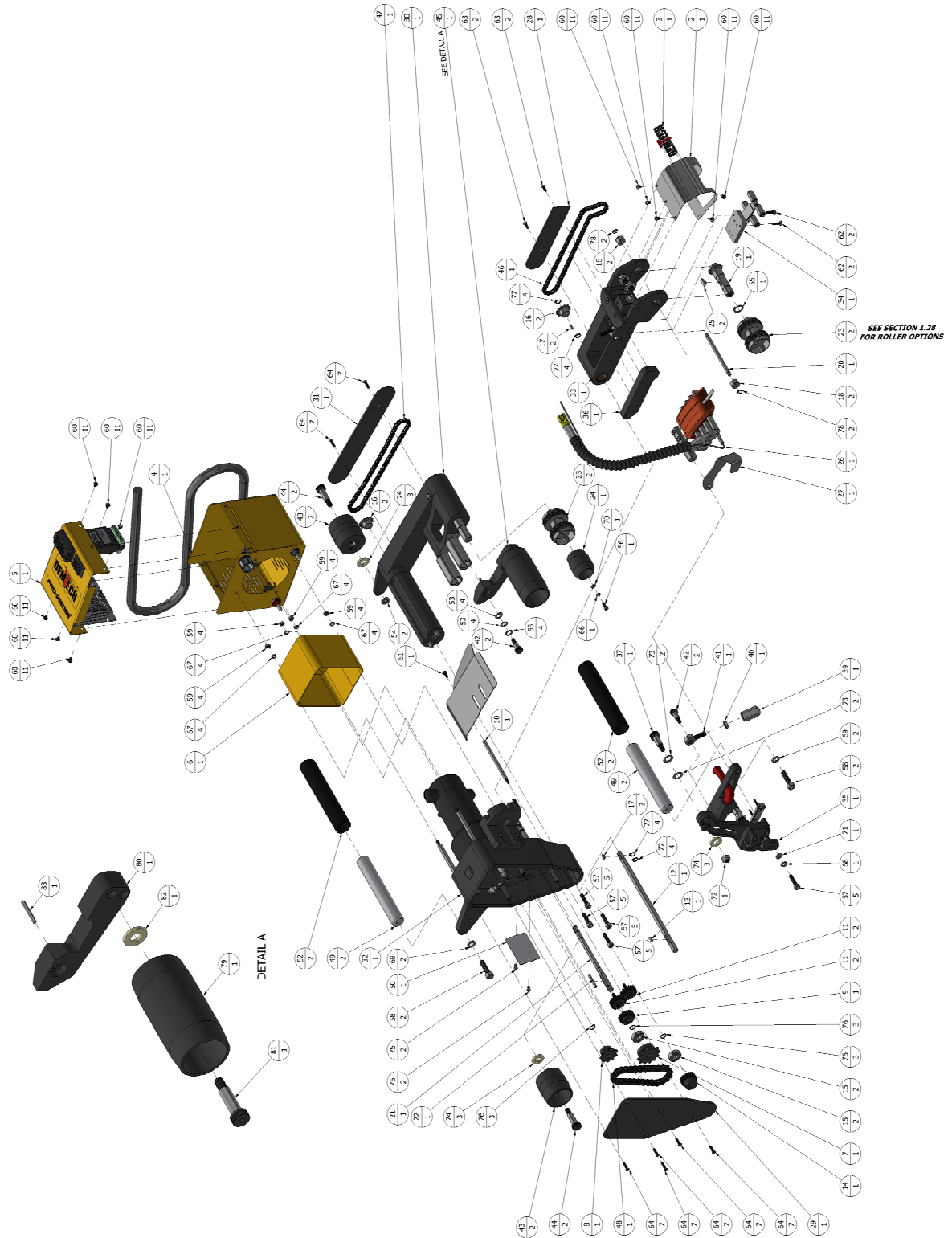

**1.1 ProWedgeAU/A – ASSY, 2” WEDGE WELDER
(Parts ID)**

PARTS LIST			
REF. NO	PART NUMBER	DESCRIPTION	QTY
1	100-002	MATERIAL GUIDE, WELDMENT	1
2	100-006A	COVER, NIP HEAD	1
3	100-006B	LABEL, DEMTECH, NIP HEAD COVER	1
4	100-016/A	ASSEMBLY, CONTROL BOX, 110V	1
5	100-017/A	ASSEMBLY, CONTROL PANEL, 120V	1
6	100-019/3	HOUSING, CONTROL BOX, SPACER	1
7	100-105	SPROCKET, NIP DRIVE, 12 TOOTH, MODIFIED	1
8	100-110	SPROCKET, NIP DRIVE, 9 TOOTH, MODIFIED	1
9	100-111	GEAR, UPPER NIP DRIVE, 20 TOOTH, MODIFIED	1
10	100-113	AXLE PIN, MATERIAL GUIDE, SHAFT	1
11	100-115/A	ASSEMBLY, IDLER GEAR	2
12	100-120/3	SHAFT, LOWER NIP, DRIVE	1
13	100-120K	KEY, LOWER NIP DRIVE SHAFT, 1/8" X 1/8" X 3/8"	1
14	100-121	GEAR, DRIVE SHAFT, 20 TOOTH, MODIFIED	1
15	100-122	BEARING, DRIVE SHAFT	2
16	100-125	SPROCKET, NIP UPPER/LOWER, 12 TOOTH, FAB/MODIFY	2
17	100-125K	KEY, SPROCKET, 1/8" X .119" X 5/16"	2
18	100-139	END SUPPORT, AXLE, UPPER NIP ROLLER	2
19	100-140/A	ASSEMBLY, UPPER NIP ROLLER W/SPROCKET HUB W/ BEARINGS	1
20	100-141	AXLE, UPPER NIP ROLLER	1
21	100-150/3	SHAFT, UPPER NIP, DRIVE	1
22	100-150K	KEY, UPPER NIP DRIVE SHAFT, 1/8" X 1/8" X 1-1/8"	1
23	100-155	NIP ROLLER, HDPE COARSE KNUURL, DUAL TRACK	2
24	100-155E	EXTENSION, NIP ROLLER, SUPPORT	1
25	100-155K	KEY, WOODRUFF, 3/16" X 5/8"	2
26	100-160A/A	ASSEMBLY, 1 3/4" (45mm) COPPER, DUAL TRACK, 110V W/ HEATERS AND T.C.	1
27	100-160G	GUARD, WEDGE HEATERS/THERMOCOUPLE	1
28	100-165.1	COVER, CHAIN, UPPER	1
29	100-175	COVER, DRIVE CHAIN	1
30	100-180/A	ASSEMBLY. LOWER FRAME	1
31	100-181	COVER, LOWER FRAME CHAIN	1
32	100-185/A	ASSEMBLY, SIDE FRAME	1
33	100-190/A	ASSEMBLY, UPPER NIP ARM	1
34	100-191/A.4	ASSEMBLY, UPPER CONTOUR ROLLER, (DOUBLE/TRIPLE), FOR THICK OR TEXTURED HDPE	1
35	100-200AU/A/A.2	ASSEMBLY, AUTO ENGAGE BRACKET	1
36	100-200B/3	SPACER, WEDGE LOCK RAIL	1
37	100-205B	SCREW, SHOULDER, 10mm DIA X 20mm LONG X M8 THREAD, ALLOY STEEL	1
38	100-205T/A	ASSEMBLY, TRIGGER / NIP PRESSURE LEVER	1
39	100-210	HEX NUT, NIP PRESSURE	1
40	100-210A	JAM NUT, NIP PRESSURE	1
41	100-212A/A	ASSEMBLY, EYE BOLT W/ BUSHING	1

***1.2 ProWedgeAU/A – ASSY, 2” WEDGE WELDER
(Parts List)***

PARTS LIST			
REF. NO	PART NUMBER	DESCRIPTION	QTY
42	100-212C	SCREW, SHOULDER, 8mm DIA X 12mm LONG X M6 THREAD, ALLOY STEEL	2
43	100-225/A	ASSEMBLY, FRONT TRAVEL ROLLER	2
44	100-226	AXLE BOLT, TRAVEL ROLLER, FRONT, M10 X 25	2
45	100-277/A	ASSEMBLY, RAISED REAR TRAVEL ROLLER	1
46	100-300.1	CHAIN, UPPER NIP, #25	1
47	100-305	CHAIN, LOWER NIP	1
48	100-310	CHAIN, DRIVE, #35	1
49	100-325	HANDLE, CORE PIN	2
50	100-399	PLATE, SERIAL, PRO-WEDGE	1
51	100-400K	KEY, MOTOR, 1/8" X 1/8" X 7/16"	1
52	500-103AXL	GRIP, REAR HANDLE	2
53	NS-HARDWARE	SHIM WASHER, 8.14mm ID X 13.90mm OD X 0.5mm THICK, STAINLESS STEEL	4
54	NS-HARDWARE	NUT, HEX JAM, M8 X 1.25 X 13mm WIDE X 4mm HIGH, 18-8 STAINLESS STEEL	2
55	NS-HARDWARE	RING, RETAINING, EXTERNAL, 15mm SHAFT, STAINLESS STEEL	1
56	NS-HARDWARE	SCREW, M4 X 0.7 X 12mm LONG, SOCKET HEAD CAP, 18-8 STAINLESS STEEL	1
57	NS-HARDWARE	SCREW, M6 X 1 X 25mm LONG, SOCKET HEAD CAP, 18-8 STAINLESS STEEL	5
58	NS-HARDWARE	SCREW, M8 X 1.25 X 30mm LONG, SOCKET HEAD CAP, 18-8 STAINLESS STEEL	2
59	NS-HARDWARE	NUT, HEX, M5 X 0.8 X 8mm WIDE X 4mm HIGH, 18-8 STAINLESS STEEL	4
60	NS-HARDWARE	SCREW, M4 X 0.7 X 5mm LONG, PAN HEAD PHILLIPS, 18-8 STAINLESS STEEL	11
61	NS-HARDWARE	SCREW, M4 X 0.7 X 10mm LONG, PAN HEAD PHILLIPS, 18-8 STAINLESS STEEL	1
62	NS-HARDWARE	SCREW, M4 X 0.7 X 16mm LONG, PAN HEAD PHILLIPS, 18-8 STAINLESS STEEL	2
63	NS-HARDWARE	SCREW, M4 X 0.7 X 12mm LONG, FLAT HEAD PHILLIPS, 18-8 STAINLESS STEEL	2
64	NS-HARDWARE	SCREW, M4 X 0.7 X 16mm LONG, FLAT HEAD PHILLIPS, 18-8 STAINLESS STEEL	7
65	NS-HARDWARE	SCREW, M3 X 0.5 X 18mm LONG, FLAT HEAD PHILLIPS, 18-8 STAINLESS STEEL	4
66	NS-HARDWARE	WASHER, M4 REGULAR SPLIT LOCK, 18-8 STAINLESS STEEL	1
67	NS-HARDWARE	WASHER, M5 REGULAR SPLIT LOCK, 18-8 STAINLESS STEEL	4
68	NS-HARDWARE	WASHER, M6 REGULAR SPLIT LOCK, 18-8 STAINLESS STEEL	1
69	NS-HARDWARE	WASHER, M8 REGULAR SPLIT LOCK, 18-8 STAINLESS STEEL	2
70	NS-HARDWARE	WASHER, M4 FLAT, 4.3mm ID X 9mm OD X 0.8mm THICK, 18-8 STAINLESS STEEL	1
71	NS-HARDWARE	WASHER, M6 FLAT, 6.4mm ID X 12mm OD X 1.6mm THICK, 18-8 STAINLESS STEEL	1
72	NS-HARDWARE	NUT, HEX, M8 X 1.25 X 13mm WIDE X 8mm HIGH, NYLON-INSERT LOCK, 18-8 STAINLESS STEEL	1
73	NS-HARDWARE	SPRING, BELLEVILLE DISC, 10.2mm ID X 18.6mm OD X 0.7mm THICK, HIGH-CARBON STEEL	2
74	NS-HARDWARE	WASHER, 10.5mm ID X 22mm OD X 2.5mm THICK, OFF-WHITE NYLON	3
75	NS-HARDWARE	RIVET, 1/8" BLIND, DOME STYLE, STAINLESS STEEL	2
76	NS-HARDWARE	RING, RETAINING, EXTERNAL, 3/8" SHAFT, BLACK FINISH STEEL	3
77	NS-HARDWARE	RING, RETAINING, EXTERNAL, 8mm SHAFT, BLACK FINISH STEEL	4
78	NS-HARDWARE	RING, RETAINING, EXTERNAL, 6-8mm SHAFT, BLACK-FINISH STEEL	2
79	100-225W/A	ASSEMBLY, REAR TRAVEL ROLLER, WIDE	1
80	100-240	BRACKET, TRAVEL ROLLER, REAR	1
81	100-275	BOLT, RAISED REAR TRAVEL ROLLER	1
82	NS-HARDWARE	WASHER, 10.5mm ID X 22mm OD X 2.5mm THICK, OFF-WHITE NYLON	1
83	NS-HARDWARE	PIN, DOWEL, 1/8" DIA X 1" LONG, 416 STAINLESSS STEEL	1

**1.3 ProWedgeAU/A – ASSY, 2" WEDGE WELDER CONTD.
(Parts List)**



1.4 100-200AU/KIT/A.2 – ASSY, AUTO ENGAGE KIT (Parts ID)

PARTS LIST			
REF. NO	PART NO	DESCRIPTION	QTY
1	100-200AU/A	ASSEMBLY, AUTO ENGAGE BRACKET	1
2	100-205T/A	ASSEMBLY, TRIGGER / NIP PRESSURE LEVER	1
3	100-200AU	BRACKET, WEDGE QUICK ENGAGE	1
4	100-200L	LOCK MOUNT, WEDGE SLIDE, LOWER	1
5	100-200M	CLAMP, HEATER CONDUIT	1
6	100-324AU	RAIL, LINEAR GUIDE W/ CARRIAGE, LONG	1
7	NS-HARDWARE	SCREW, M4 X 0.7 X 14mm LONG, SOCKET HEAD CAP, 18-8 STAINLESS STEEL	2
8	NS-HARDWARE	SCREW, M4 X 0.7 X 20mm LONG, SOCKET HEAD CAP, 18-8 STAINLESS STEEL	2
9	NS-HARDWARE	SCREW, M3 X 0.5 X 22mm LONG, SOCKET HEAD CAP, 18-8 STAINLESS STEEL	4
10	NS-HARDWARE	SCREW, M3 X 0.5 X 18mm LONG, FLAT HEAD PHILLIPS, 18-8 STAINLESS STEEL	4
11	NS-HARDWARE	WASHER, M4 REGULAR SPLIT LOCK, 18-8 STAINLESS STEEL	2
12	NS-HARDWARE	WASHER, M4 FLAT, 4.3mm ID X 9mm OD X 0.8mm THICK, 18-8 STAINLESS STEEL	2
13	100-199.1/A	ASSEMBLY, LOCK PIN	1
14	100-201AU	BUSHING, 6mm ID X 10mm OD X 10mm LONG, OIL IMPREGNATED BRONZE	1
15	100-205A	LEVER, NIP PRESSURE, PIVOT	1
16	100-205C	SLEEVE BEARING, 10mm ID X 12mm OD X 12mm LONG, PTFE-LINED TIN BRONZE / STEEL	1
17	100-205D	BEARING, NEEDLE ROLLER, 8mm ID X 12mm OD X 10mm LONG, SINGLE SEAL	2
18	100-205E	SCREW, SHOULDER, 8mm DIA X 30mm LONG X M6 THREAD, ALLOY STEEL	1
19	100-205F	WASHER, FLAT, .140" ID X .410" OD X .040" THICK, WHITE ACETAL	2
20	100-205G	WASHER, TRIPLE-WAVE, .205" ID X .375" OD X .005 THK X .041" FH, 18-8 STAINLESS STEEL	2
21	100-205T	TRIGGER, NIP LEVER RELEASE	1
22	NS-HARDWARE	ADHESIVE, THREADLOCKING LIQUID, RED	1
23	NS-HARDWARE	WASHER, 8.4mm ID X 18mm OD X 2.0mm THICK, OFF-WHITE NYLON	1
24	NS-HARDWARE	GREASE, TriGel-600SM, 4 OZ TUBE	5

1.5 100-200AU/KIT/A – ASSY, AUTO ENGAGE KIT (Parts List)

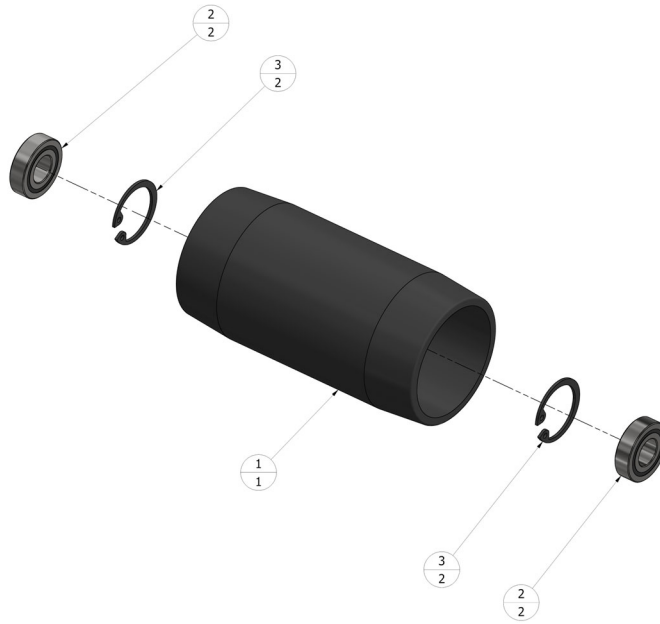

**1.6 100-225W/A – ASSY, REAR TRAVEL ROLLER, WIDE
(Parts ID)**

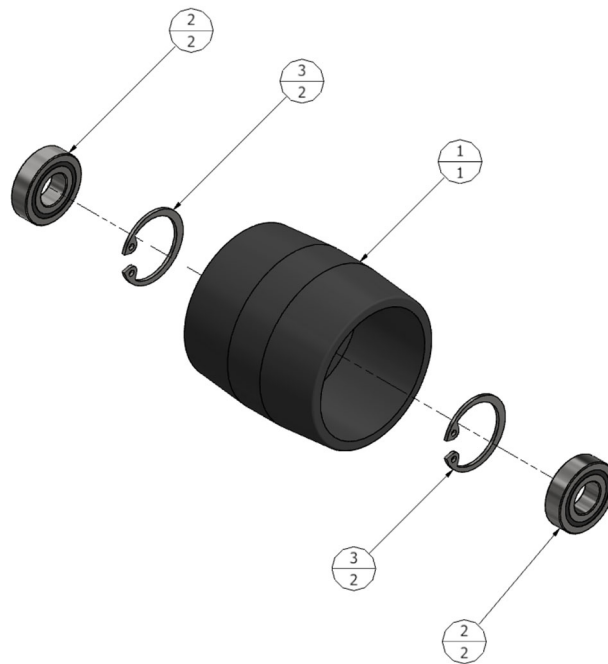

**1.7 100-225/A – ASSY, FRONT TRAVEL ROLLER
(Parts ID)**

PARTS LIST			
REF. NO	PART NO	DESCRIPTION	QTY
1	100-225W	TRAVEL ROLLER, REAR, WIDE	1
2	100-232.1	BEARING, TRAVEL ROLLER, FRONT	2
3	NS-HARDWARE	RING, RETAINING, INTERNAL, 22mm BORE, BLACK FINISH STEEL	2

**1.8 100-225W/A – ASSY, REAR TRAVEL ROLLER, WIDE
(Parts List)**

PARTS LIST			
REF. NO	PART NO	DESCRIPTION	QTY
1	100-225	TRAVEL ROLLER, FRONT	1
2	100-232.1	BEARING, TRAVEL ROLLER, FRONT	2
3	NS-HARDWARE	RING, RETAINING, INTERNAL, 22mm BORE, 400 STAINLESS STEEL	2

1.9 100-225/A – ASSY, FRONT TRAVEL ROLLER (Parts List)

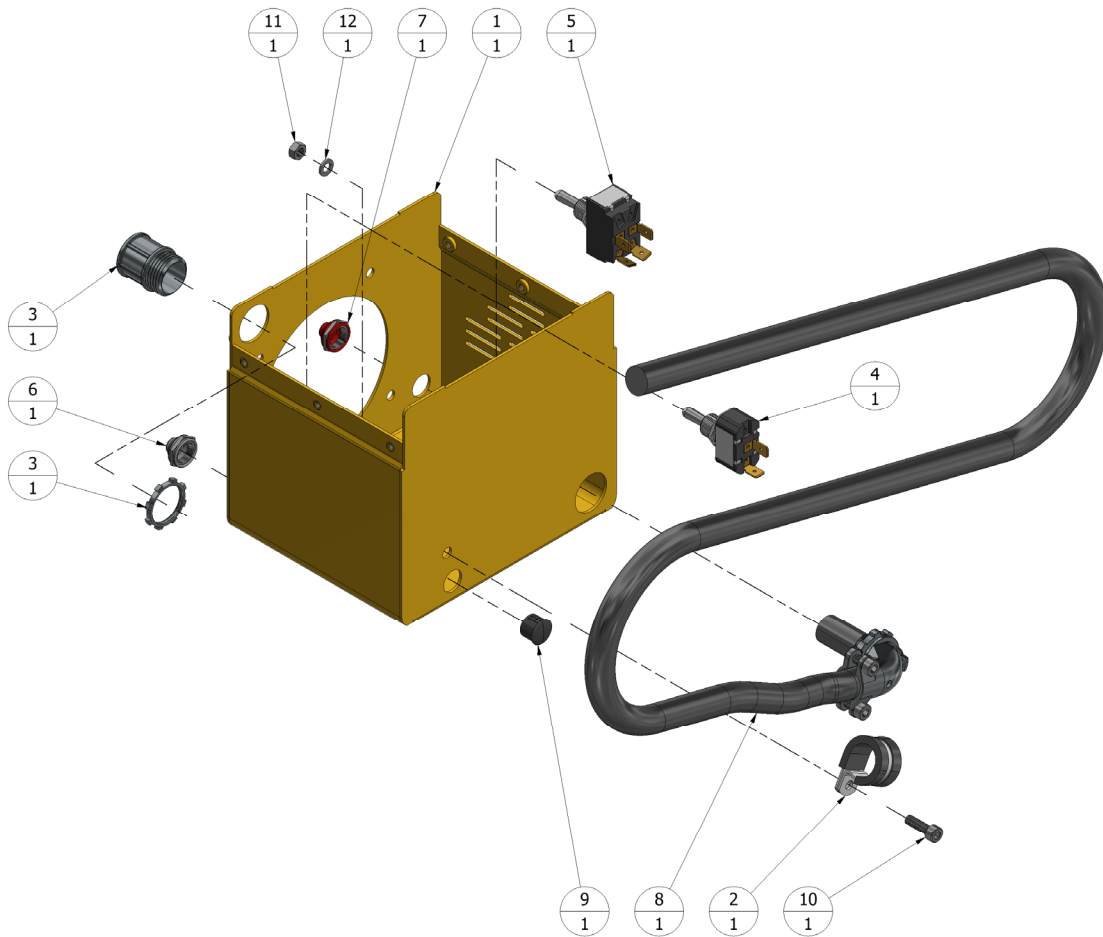

1.10 100-016/A – ASSY, CONTROL BOX, 110V & 220V (Parts ID)

PARTS LIST			
REF. NO	PART NO	DESCRIPTION	QTY
1	100-016	BOX, CONTROL, BOTTOM	1
2	100-235	MOUNT, CONDUIT	1
3	100-446	FITTING, CONDUIT	1
4	100-450	SWITCH, ON/OFF, MOTOR, 2 POLE	1
5	100-450.1	TOGGLE SWITCH, ON/OFF (POWER), 4 POLE	1
6	100-451	BOOT, ON/OFF SWITCH (GREY)	1
7	100-451.1	BOOT, ON/OFF, POWER (RED)	1
8	100-CORD/ProWedge/A	ASSEMBLY, POWER CORD, 120V & 220V W/O PLUG	1
9	NS-HARDWARE	PLUG, 1/2" UNVENTED NYLON DOME, LOCKING, BLACK	1
10	NS-HARDWARE	SCREW, M5 X 0.8 X 16mm LONG, SOCKET HEAD CAP, 18-8 STAINLESS STEEL	1
11	NS-HARDWARE	NUT, HEX, M5 X 0.8 X 8mm WIDE X 4mm HIGH, 18-8 STAINLESS STEEL	1
12	NS-HARDWARE	WASHER, M5 REGULAR SPLIT LOCK, 18-8 STAINLESS STEEL	1

1.11 100-016/A – ASSY, CONTROL BOX, 110V & 220V (Parts List)

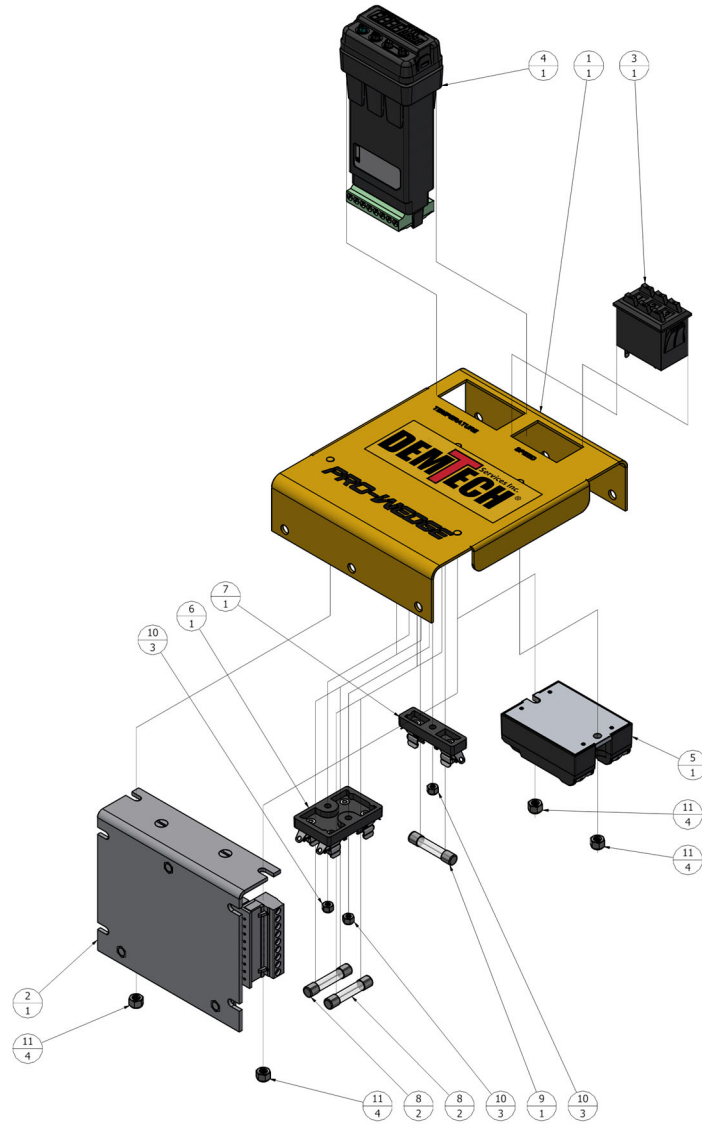

1.12 100-017/A – ASSY, CONTROL PANEL, 120V (Parts ID)

PARTS LIST			
REF. NO	PART NO	DESCRIPTION	QTY
1	100-017	LID, CONTROL PANEL	1
2	100-415	CONTROL BOARD, MOTOR, 110V	1
3	100-416	POTENTIOMETER, PUSH BUTTON, MOTOR	1
4	100-426	CONTROLLER, TEMPERATURE, EZ-ZONE	1
5	100-431	RELAY, SOLID STATE, 25A, 3-32VDC, 240V	1
6	100-455.1	FUSE HOLDER, DOUBLE	1
7	100-455.2	FUSE HOLDER, SINGLE	1
8	100-456	FUSE, 20 AMP (110V MODEL)	2
9	100-457	FUSE, 1.5 AMP	1
10	NS-HARDWARE	NUT, M3 X 0.5 X 5.5mm WIDE X 4mm HIGH, HEX LOCK, NYLON-INSERT	3
11	NS-HARDWARE	NUT, M4 X 0.7 X 5.3mm WIDE X 5.3mm HIGH, HEX LOCK, NYLON-INSERT	4

1.13 100-017/A – ASSY, CONTROL PANEL, 120V (Parts List)

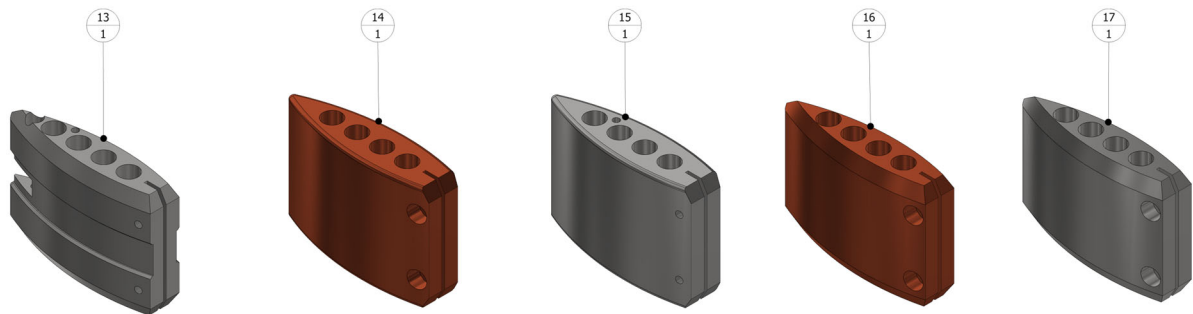
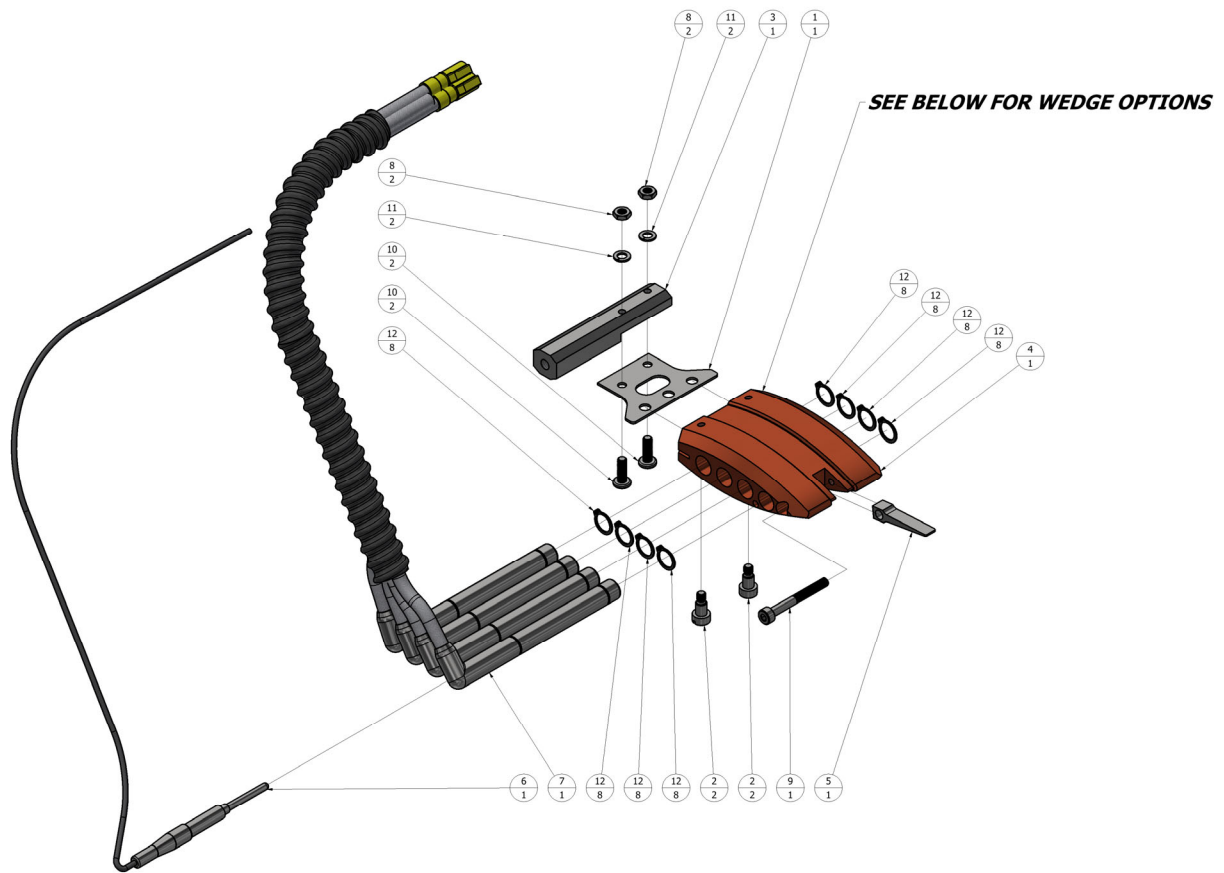

ALTERNATE WEDGE STYLES FOR EITHER 110V OR 220V ASSY VERSIONS

1.14 100-160A/A ASSY, 3/4" (45mm) COPPER, DUAL TRACK, 110V (Parts ID)

PARTS LIST			
REF. NO	PART NUMBER	DESCRIPTION	QTY
1	100-159B	MOUNT, PLATE (NEW)	1
2	100-159C	SHOULDER BOLT, WEDGE MOUNT, 5mm DIA X 6mm LONG	2
3	100-159D/3	MOUNT, HEX, 3" PRO-WEDGE	1
4	100-160A	WEDGE, 1-3/4", COPPER, SPLIT, SINGLE MOUNT	1
5	100-160B	FINGER, FLOATING, AIR CHANNEL	1
6	100-435	ASSEMBLY, THERMOCOUPLE	1
7	100-440/A	ASSEMBLY, CARTRIDGE HEATER SET, 110V, 400W	1
8	NS-HARDWARE	NUT, HEX JAM, M4 X 0.7 X 7mm WIDE X 2.2mm HIGH, 18-8 STAINLESS STEEL	2
9	NS-HARDWARE	SCREW, M4 X 0.7 X 35mm LONG, SOCKET HEAD CAP, 18-8 STAINLESS STEEL	1
10	NS-HARDWARE	SCREW, M4 X 0.7 X 12mm LONG, PAN HEAD PHILLIPS, 18-8 STAINLESS STEEL	2
11	NS-HARDWARE	WASHER, M4 REGULAR SPLIT LOCK, 18-8 STAINLESS STEEL	2
12	NS-HARDWARE	RING, RETAINING, EXTERNAL, 3/8" SHAFT, STAINLESS STEEL	8
13	100-160AS	WEDGE, 1-3/4" (45mm), STAINLESS STEEL, DUAL TRACK	1
14	100-161	WEDGE, 2" (50mm), COPPER, SINGLE TRACK	1
15	100-161AS	WEDGE, 2" (50mm), STAINLESS STEEL, SINGLE TRACK	1
16	100-163A	WEDGE, 1 3/4" (45mm), COPPER, SINGLE TRACK	1
17	100-163AS	WEDGE, 1 3/4" (45mm), STAINLESS STEEL, SINGLE TRACK	1

***1.15 100-160A/A – ASSY, 2" (50mm) WEDGE, SOLID, COPPER, 110V
(Parts List)***



1.16 100-16XXX – ASSEMBLED WEDGE OPTIONS (Parts ID)

PARTS LIST			
REF. NO	PART NO	DESCRIPTION	QTY
1	100-160A/A	WEDGE ASS'Y, 1 3/4" (45mm), COPPER, DUAL TRACK, 110V W/ HEATERS AND T.C.	1
1	100-160A/A.2	WEDGE ASS'Y, 1 3/4" (45mm), COPPER, DUAL TRACK, 220V W/ HEATERS AND T.C.	1
2	100-160AS/A	WEDGE ASS'Y, 1 3/4" (45mm), STAINLESS STEEL, DUAL TRACK, 110V W/ HEATERS & T.C.	1
2	100-160AS/A.2	WEDGE ASS'Y, 1 3/4" (45mm), STAINLESS STEEL, DUAL TRACK, 220V W/ HEATERS & T.C.	1
3	100-161/A	WEDGE ASS'Y, 2" (50mm), COPPER, SINGLE TRACK, 110V W/ HEATERS & T.C.	1
3	100-161/A.2	WEDGE ASS'Y, 2" (50mm), COPPER, SINGLE TRACK, 220V W/ HEATERS & T.C.	1
4	100-161AS/A	WEDGE ASS'Y, 2" (50mm), STAINLESS STEEL, SINGLE TRACK, 110V W/ HEATERS AND T.C.	1
4	100-161AS/A.2	WEDGE ASS'Y, 2" (50mm), STAINLESS STEEL, SINGLE TRACK, 220V W/ HEATERS AND T.C.	1
5	100-163A/A	WEDGE ASS'Y, 1 3/4" (45mm), COPPER, SINGLE TRACK, 110V W/ HEATERS & T.C.	1
5	100-163A/A.2	WEDGE ASS'Y, 1 3/4" (45mm), COPPER, SINGLE TRACK, 220V W/ HEATERS & T.C.	1
6	100-163AS/A	WEDGE ASS'Y, 1 3/4" (50mm), STAINLESS STEEL, SINGLE TRACK, 110V W/ HEATERS & T.C.	1
6	100-163AS/A.2	WEDGE ASS'Y, 1 3/4" (50mm), STAINLESS STEEL, SINGLE TRACK, 220V W/ HEATERS & T.C.	1

1.17 100-16XXXX – ASSEMBLED WEDGE OPTIONS (Parts List)

PARTS LIST			
REF. NO	PART NO	DESCRIPTION	QTY
1	100-122	BEARING, DRIVE SHAFT	1
2	100-125	SPROCKET, NIP UPPER/LOWER, 12 TOOTH, FAB/MODIFY	1
3	100-125K	KEY, SPROCKET, 1/8" X .119" X 5/16"	1
4	100-145	SHAFT, LOWER NIP	1
5	100-146	BEARING, LOWER NIP SHAFT	2
6	100-165A	STANDOFF, MALE/FEMALE, M4 X 0.7, STAINLESS STEEL	2
7	100-180	FRAME, LOWER	1
8	100-182	SCREW, LOWER NIP SHAFT, RETENTION	1
9	100-183	BRACKET, CHAIN TENSIONER, ADJUSTMENT	1
10	100-183L	BRACKET, CHAIN TENSION ADJUST, LONG	1
11	100-186/3	FRAME, CROSS	1
12	100-215B	PLATE, CAM MOUNT	1
13	100-220A/A	ASSEMBLY, LOWER CONTOUR ROLLER	2
14	NS-HARDWARE	SCREW, M8 X 1.25 X 25mm LONG, HEX HEAD CAP, 18-8 STAINLESS STEEL	1
15	NS-HARDWARE	SCREW, M6 X 1 X 20mm LONG, SOCKET HEAD CAP, 18-8 STAINLESS STEEL	4
16	NS-HARDWARE	SCREW, M8 X 1.25 X 80mm LONG, SOCKET HEAD CAP, 18-8 STAINLESS STEEL	1
17	NS-HARDWARE	SCREW, M5 X 0.8 X 8mm LONG, PAN HEAD PHILLIPS, 18-8 STAINLESS STEEL	1
18	NS-HARDWARE	SCREW, SET, M5 X 0.8 X 6mm LONG, ALLEN CUP POINT, 18-8 STAINLESS STEEL	1
20	NS-HARDWARE	O-RING, .609" ID X .139" CS, 70 SHORE A, BLACK BUNA-N	1
21	NS-HARDWARE	RING, RETAINING, EXTERNAL, 19/32" SHAFT, BLACK FINISH STEEL	1
22	NS-HARDWARE	PIN, DOWEL, 1/4" OD X 3/4" LONG, 416 STAINLESS STEEL	4
23	NS-HARDWARE	RING, RETAINING, EXTERNAL, 8mm SHAFT, BLACK FINISH STEEL	1
24	NS-HARDWARE	RING, RETAINING, INTERNAL, 7/8" BORE, BLACK FINISH STEEL	3
25	100-215A	CAM MOUNT, CONTOUR ROLLER, LOWER	1
26	100-220A	CONTOUR ROLLER, LOWER, TAPERED	1
27	100-221	BEARING, CONTOUR ROLLER, LOWER	2
28	NS-HARDWARE	SCREW, M5 X 0.8 X 10mm LONG, SOCKET HEAD CAP, 18-8 STAINLESS STEEL	1
29	NS-HARDWARE	WASHER, M5 REGULAR SPLIT LOCK, 18-8 STAINLESS STEEL	1
30	NS-HARDWARE	RING, RETAINING, INTERNAL, 3/4" BORE, ZINC CHROMATE PLATED STEEL	2

1.19 100-180/A – ASSY, LOWER FRAME (Parts List)

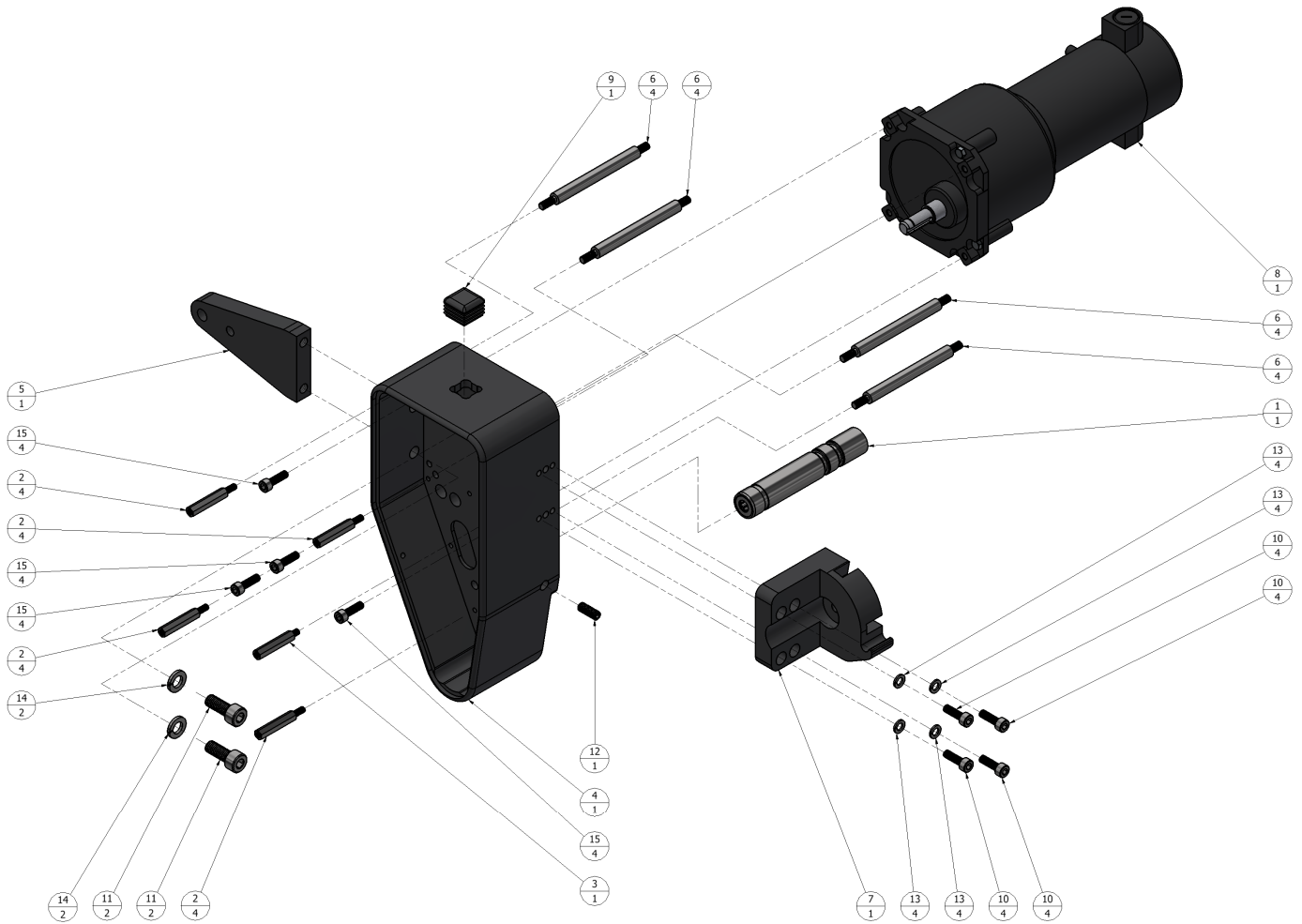

1.20 100-185/A – ASSY, SIDE FRAME (Parts ID)

Parts ID			
REF. NO	PART NO	DESCRIPTION	QTY
1	100-151/3/A	ASSEMBLY, UPPER NIP DRIVE SHAFT HOUSING	1
2	100-175A	STANDOFF, M4 X 0.7 X 31mm LONG HEX, MALE-FEMALE, 18-8 STAINLESS STEEL	4
3	100-175AS	STANDOFF, M4 X 0.7 X 31mm LONG HEX, MALE-FEMALE, 18-8 STAINLESS STEEL, MODIFIED	1
4	100-185	FRAME, SIDE	1
5	100-185A	BRACKET, SIDE FRAME, HANDLE	1
6	100-187/3	STANDOFF, SPACER	4
7	100-206A/3.1	MOUNT, NIP PRESSURE LEVER, 5mm SCREW	1
8	100-400	MOTOR, DRIVE, MODEL 0161, MODIFIED	1
9	NS-HARDWARE	PLUG, SQUARE, 3/4", PVC	1
10	NS-HARDWARE	SCREW, M5 X 0.8 X 16mm LONG, SOCKET HEAD CAP, 18-8 STAINLESS STEEL	4
11	NS-HARDWARE	SCREW, M8 X 1.25 X 20mm LONG, SOCKET HEAD CAP, 18-8 STAINLESS STEEL	2
12	NS-HARDWARE	SCREW, SET, M6 X 1 X 16mm LONG, ALLEN CUP POINT, 18-8 STAINLESS STEEL	1
13	NS-HARDWARE	WASHER, M5 REGULAR SPLIT LOCK, 18-8 STAINLESS STEEL	4
14	NS-HARDWARE	WASHER, M8 REGULAR SPLIT LOCK, 18-8 STAINLESS STEEL	2
15	NS-HARDWARE	SCREW, 10-32 X 5/8" LONG, SOCKET HEAD CAP, 18-8 STAINLESS STEEL	4

1.21 100-185/A – ASSY, SIDE FRAME (Parts List)

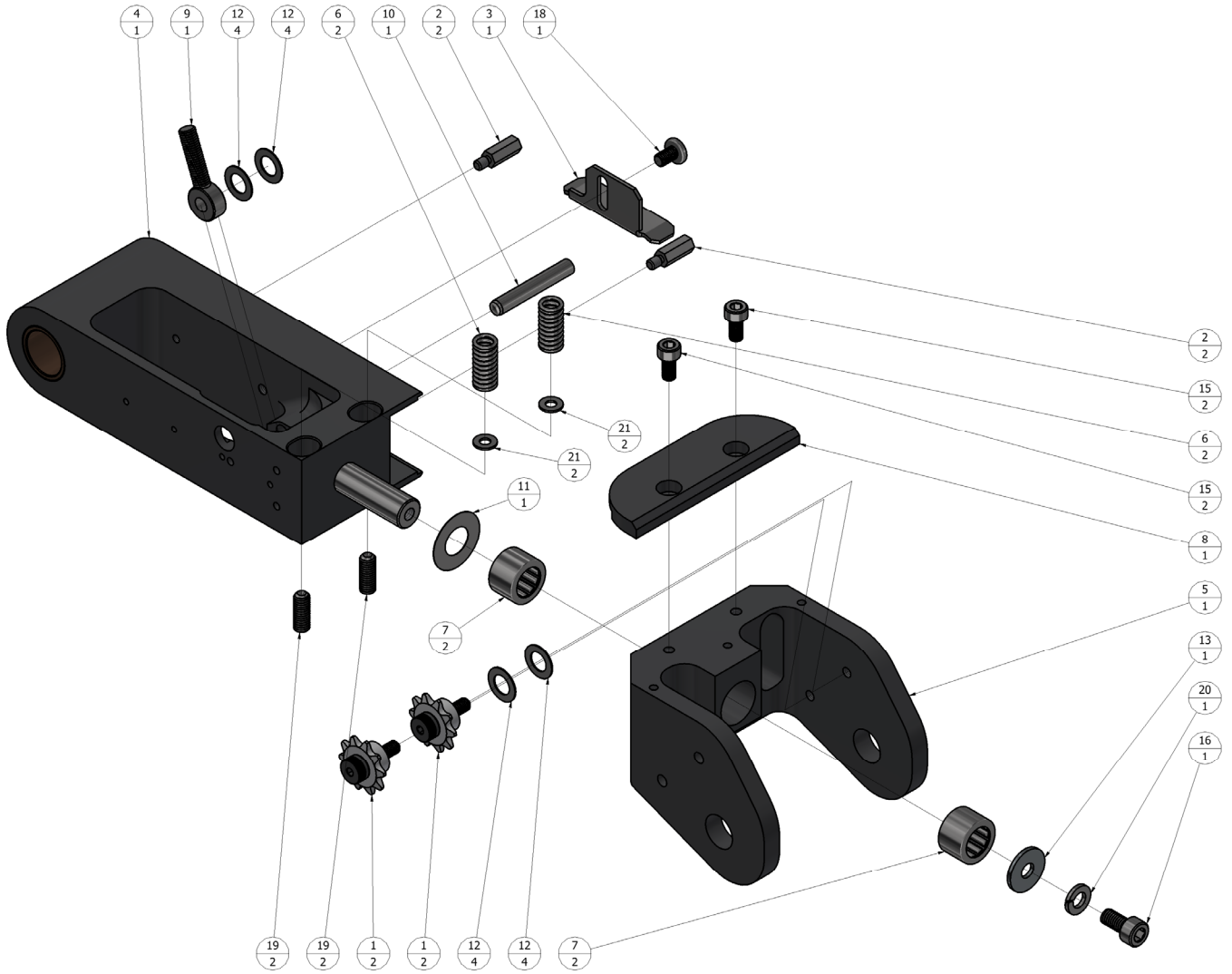

1.22 100-190/A – ASSY, UPPER NIP ARM (Parts ID)

PARTS LIST			
REF. NO	PART NUMBER	DESCRIPTION	QTY
1	100-130/A	ASSEMBLY, IDLER SPROCKET	2
2	100-165A	STANDOFF, MALE/FEMALE, M4 X 0.7, STAINLESS STEEL	2
3	100-183	BRACKET, CHAIN TENSIONER, ADJUSTMENT	1
4	100-190/189	ARM, NIP HEAD, W/ MAIN SHAFT	1
5	100-195	HEAD, NIP	1
6	100-196.1	SPRING, COMPRESSION, .360" OD X 1.000" LONG X .055" WIRE, STAINLESS STEEL	2
7	100-197	BEARING, NIP HEAD	2
8	100-198	PLATE, NIP HEAD, SPRING	1
9	100-211	EYE BOLT, RIGHT-HAND THREAD	1
10	100-213	DOWEL PIN, NIP PRESSURE ADJUSTMENT, 6mm DIA X 40mm LONG, HARDENED STEEL	1
11	NS-HARDWARE	SHIM WASHER, 12mm ID X 24mm OD X 0.2mm THICK, STAINLESS STEEL	1
12	NS-HARDWARE	SHIM WASHER, 8.14mm ID X 13.90mm OD X 0.5mm THICK, STAINLESS STEEL	4
13	NS-HARDWARE	WASHER, FLAT, M6 OVERSIZED, 6.4mm ID X 18mm OD X 1.6mm THICK, ZINC-PLATED STEEL	1
14	NS-HARDWARE	SCREW, SET, M5 X 0.8 X 16mm LONG, ALLEN CONE POINT, ALLOY STEEL	1
15	NS-HARDWARE	SCREW, M5 X 0.8 X 10mm LONG, SOCKET HEAD CAP, 18-8 STAINLESS STEEL	2
16	NS-HARDWARE	SCREW, M6 X 1 X 12mm LONG, SOCKET HEAD CAP, 18-8 STAINLESS STEEL	1
17	NS-HARDWARE	NUT, HEX, M5 X 0.8 X 8mm WIDE X 4mm HIGH, 18-8 STAINLESS STEEL	1
18	NS-HARDWARE	SCREW, M5 X 0.8 X 8mm LONG, PAN HEAD PHILLIPS, 18-8 STAINLESS STEEL	1
19	NS-HARDWARE	SCREW, SET, M6 X 1 X 16mm LONG, ALLEN CUP POINT, 316 STAINLESS STEEL	2
20	NS-HARDWARE	WASHER, M6 REGULAR SPLIT-LOCK, 316 STAINLESS STEEL	1
21	NS-HARDWARE	WASHER, M4 FLAT, 4.3mm ID X 9mm OD X 0.8mm THICK, 18-8 STAINLESS STEEL	2

1.23 100-190/A – ASSY, UPPER NIP ARM (Parts List)

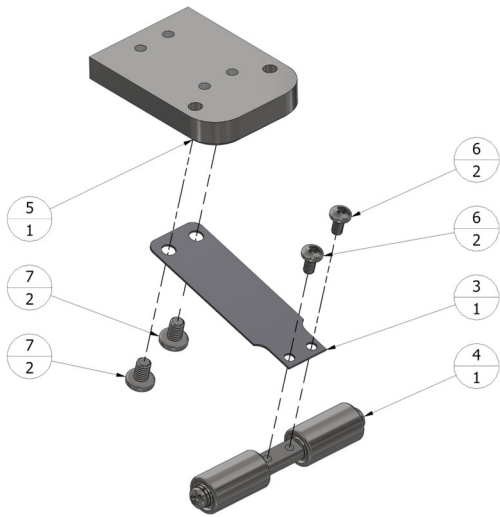

100-191/A.1, ASSY, UPPER CONTOUR ROLLER, (SINGLE LIGHT) FOR THIN FLEXIBLES

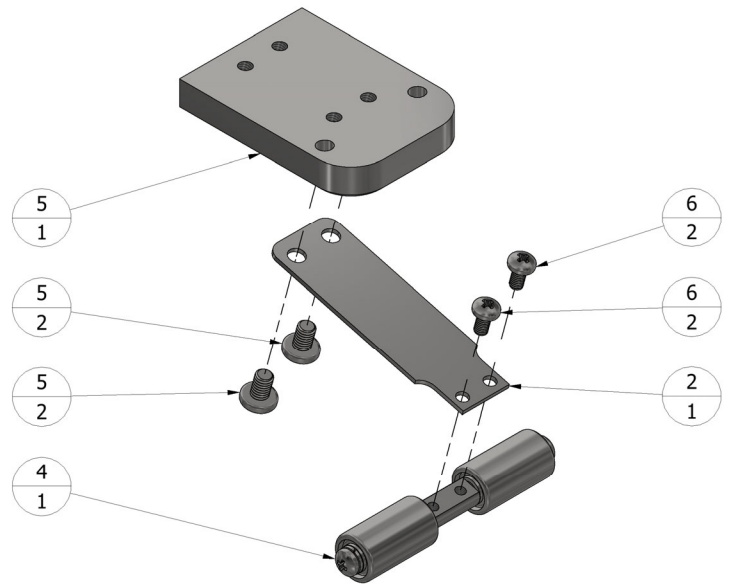

100-191/A.2, ASSY, UPPER CONTOUR ROLLER, (SINGLE REGULAR) FOR REINFORCED

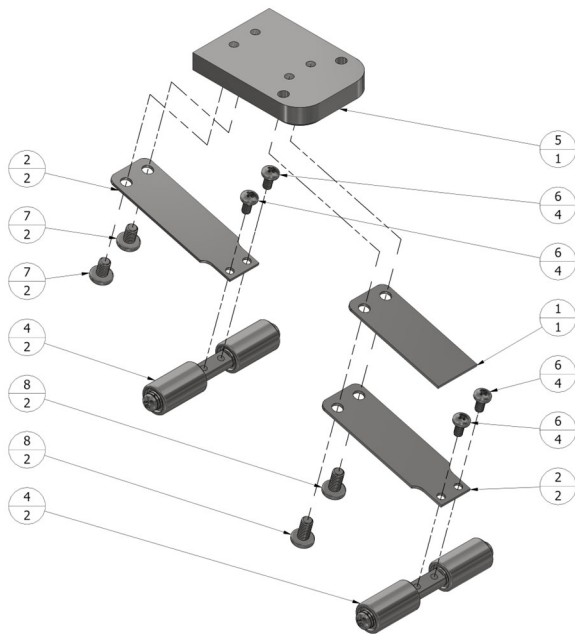

100-191/A.3, ASSY, UPPER CONTOUR ROLLER, (SINGLE/DOUBLE) FOR UP TO 40 MIL HDPE

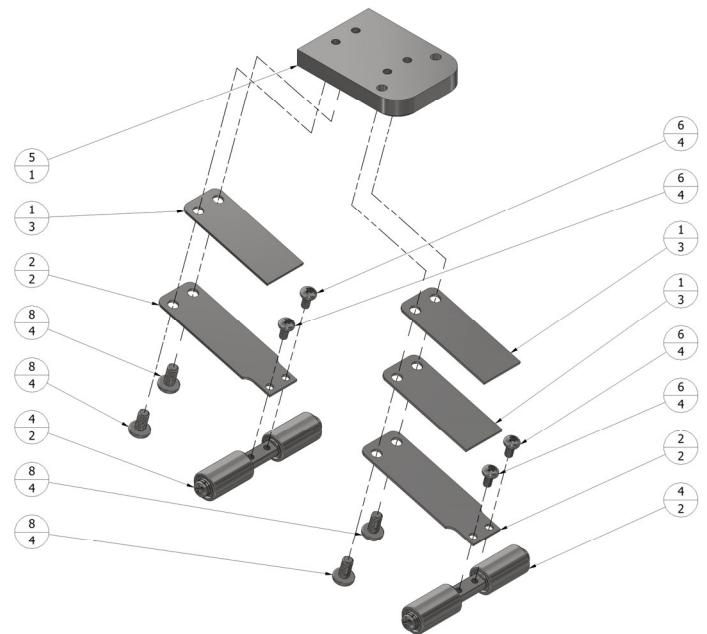

100-191/A.4, ASSY, UPPER CONTOUR ROLLER, (DOUBLE/TRIPLE) FOR 40 MIL AND THICKER HDPE

1.24 100-191/A.1, .2, .3, and .4 – ASSY, UPPER CONTOUR ROLLER (Parts ID)

PARTS LIST			
REF. NO	PART NO	DESCRIPTION	QTY
1	100-010	SPRING, CONTOUR ROLLER, UPPER, BACKUP	4
2	100-012	SPRING, W/ MOUNT, CONTOUR ROLLER, UPPER	5
3	100-012A	SPRING, W/ MOUNT, CONTOUR ROLLER, UPPER, LIGHT	1
4	100-191N/A	ASSEMBLY, UPPER CONTOUR ROLLER AXLE	6
5	100-192	PLATE, CONTOUR ROLLER UPPER, MOUNT	4
6	NS-HARDWARE	SCREW, M3 X 0.5 X 6mm LONG, PAN HEAD PHILLIPS, 18-8 STAINLESS STEEL	12
7	NS-HARDWARE	SCREW, M4 X 0.7 X 5mm LONG, PAN HEAD PHILLIPS, 18-8 STAINLESS STEEL	6
8	NS-HARDWARE	SCREW, M4 X 0.7 X 8mm LONG, PAN HEAD PHILLIPS, 18-8 STAINLESS STEEL	6

***1.25 100-191/A.1, .2, .3, and .4 – ASSY, UPPER CONTOUR ROLLER
(Parts List)***

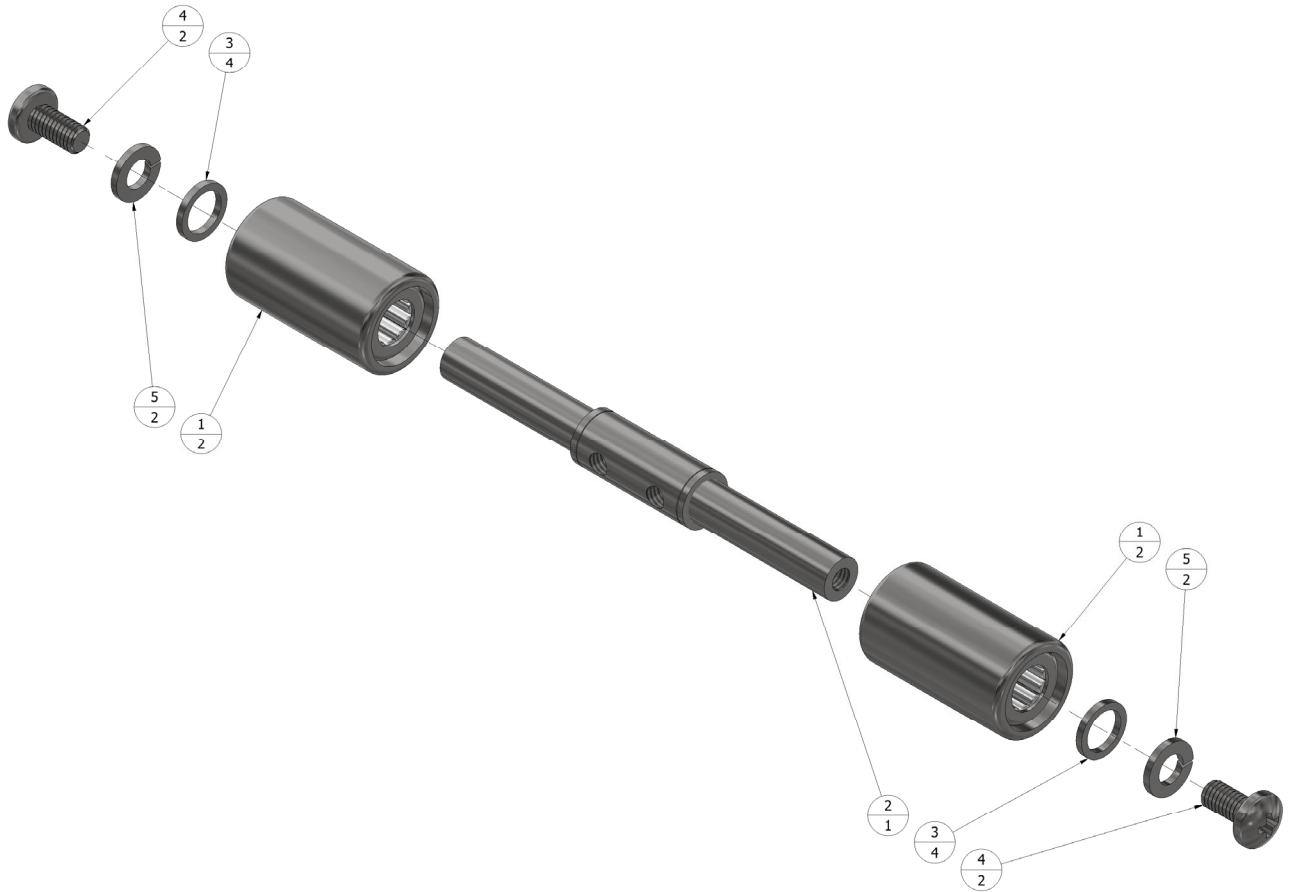

**1.26 100-191N/A – ASSY, UPPER CONTOUR ROLLER AXLE
(Parts ID)**

PARTS LIST			
REF. NO	PART NUMBER	DESCRIPTION	QTY
1	100-191/A	ASSEMBLY, CONTOUR ROLLER NEEDLE BEARING	2
2	100-193	AXLE, NEEDLE BEARING CONTOUR ROLLER, UPPER	1
3	NS-HARDWARE	SHIM, .250" OD X .187" ID X .032" THICK, STAINLESS STEEL	4
4	NS-HARDWARE	SCREW, M3 X 0.5 X 6mm LONG, PAN HEAD PHILLIPS, 18-8 STAINLESS STEEL	2
5	NS-HARDWARE	WASHER, M3 REGULAR SPLIT LOCK, 18-8 STAINLESS STEEL	2

***1.27 100-191N/A – ASSY, UPPER CONTOUR ROLLER AXLE
(Parts List)***

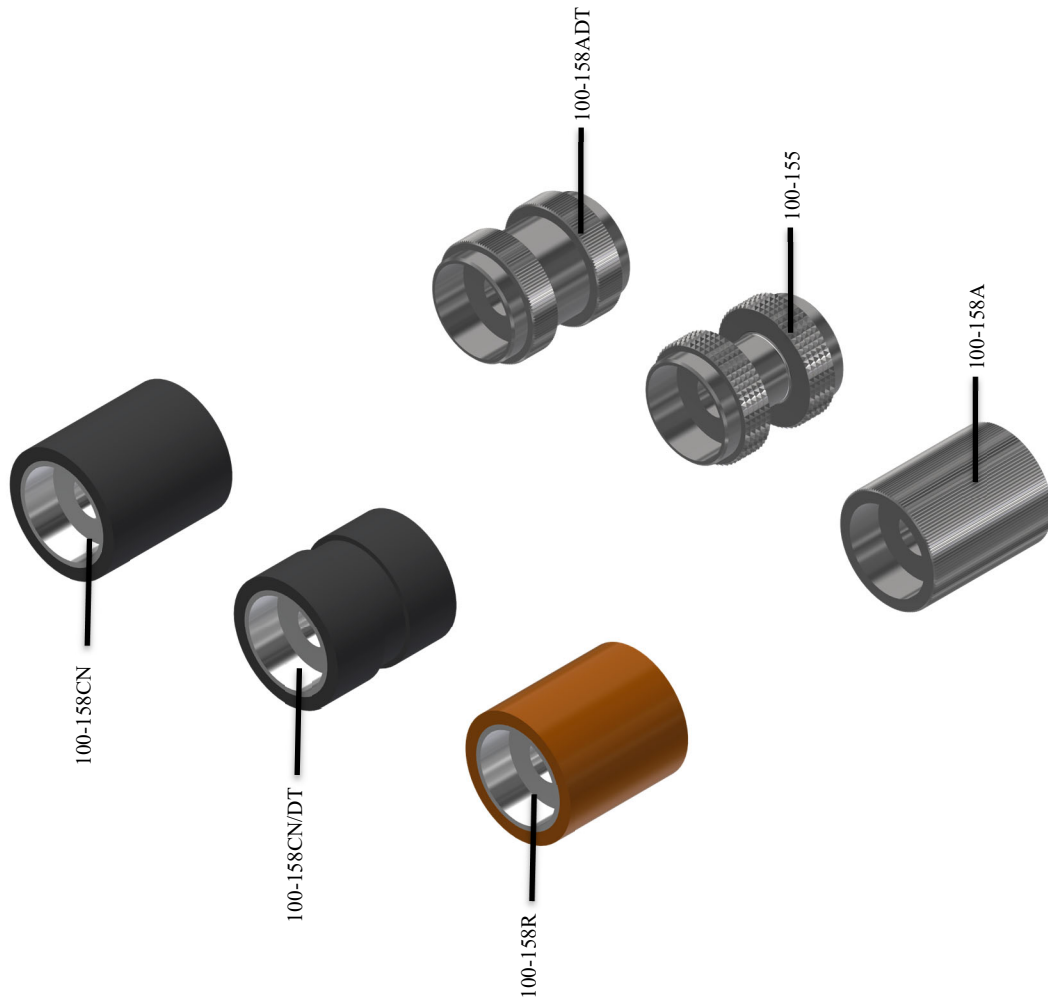

PARTS LIST	
REF. NO	DESCRIPTION
100-155	NIP ROLLER, HDPE COARSE KNURL, DUAL TRACK
100-158A	NIP ROLLER, 2" (50mm), STAINLESS STEEL, FINE KNURL, SINGLE TRACK
100-158ADT	NIP ROLLER, STAINLESS STEEL, FINE KNURL, DUAL TRACK
100-158CN	NIP ROLLER, 2" (50mm), CARBOXYLATED NITRILE, BLACK, SINGLE TRACK
100-158CN/DT	NIP ROLLER, 2" CARBOXYLATED NITRILE, DUAL TRACK, BLACK
100-158R	NIP ROLLER, 2" (50mm) SILICON RUBBER, SINGLE TRACK, TOMATO RED

1.28 100-15XXXX – NIP ROLLERS, Parts ID & Parts List